

Go2 Handheld Remote Control

User Manual V1.0

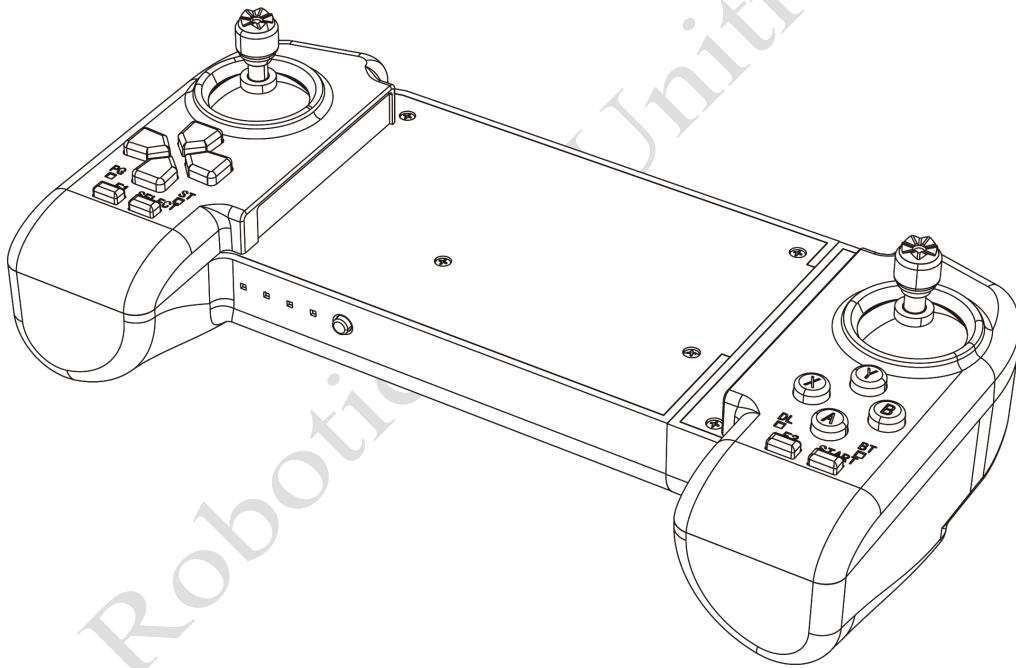

Unitree

www.unitree.com

Introduction

The handheld remote control is part of the Go2 remote control module, and the remote control handle has a installed digital transmission module and a bluetooth module. The robot dog communicates with the remote control through the data transmission module. The robot dog can be manipulated to achieve stable and full control of 3-axis posture and 3-axis position when standing. The users can manipulate the robot to move forward and backward, move left and right, spin turn and walk under certain rules (straight line, circle, rectangle), etc. on flat ground, and can even climb or walk downstairs and slopes. The remote control handle adopts a easy holding design, which makes the structure conform with ergonomic and feels more comfortable.

Parts Name

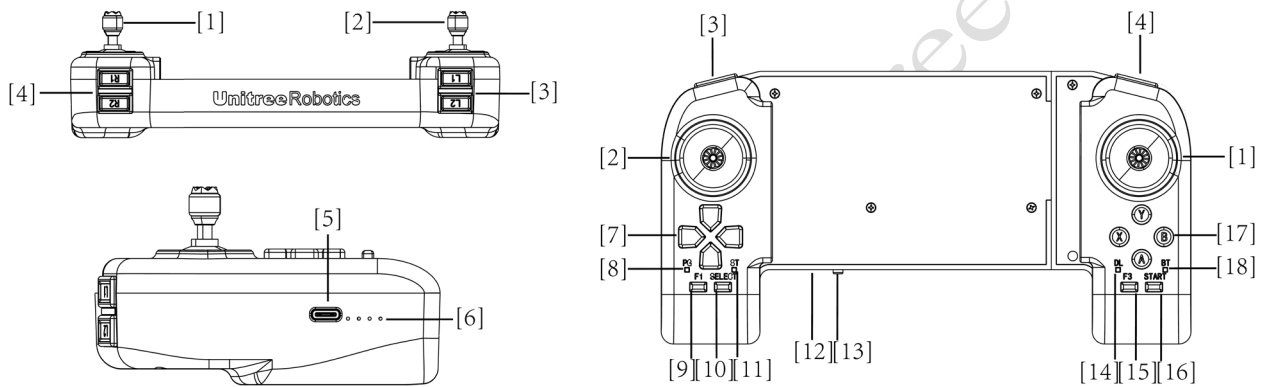

- [1] Right Rocker [2] Left Rocker [3] Key L1/L2 [4] Key R1/R2 [5] Type C Charging Interface Type C
 [6] Data Transmission Signal Light [7] Left Key [8] Power Connect Indicator
 [9] F1 Left Rocker Calibration Key [10] SELECT [11] Charging Status Indicator [12] Power Indicator Light
 [13] Power Button [14] Data Transmission Indicator Light [15] F3 Right Rocker Calibration Key
 [16] START [17] Right Key [18] Bluetooth Signal Indicator Light

Technical Specifications

Parameter	Specification	Remarks
Charging Voltage	5.0V	
Charging Current	2A	
Lithium Battery Capacity	2500mAh	
Communication Mode	Data Transmission Module, Bluetooth	
Running Time	4.5h	
Remote Control Distance	Above 100m	Open Environment

Handheld Remote Control Handle Rocker Calibration

Hold the remote control without touching the rocker, press the upper buttons F1 and F3 on the remote control and release them at the same time. At this time, the remote control will emit a continuous "beep~beep~" sound (1 time/sec) to indicate that it has entered the calibration mode. After entering the calibration mode, the users need to turn the left and right rockers to full rudder and rotate several times until the sound of "beep~beep~" stops, and the calibration is ready. Press F3 once to make the calibration take effect and complete the calibration.

 Attention! When calibrating the remote rod, please do not touch the rocker before calibration. The rocker can only be moved after entering the calibration mode.

Handheld Remote Control Turnon/Turnoff

Turn on the handheld remote control: Shortly press the power button once, then long press the power button for more than 2 seconds, and hear a "beep", which means the remote control is turned on.

Turn off the handheld remote control: Shortly press the power button once, then long press the power button for more than 2 seconds, and hear three "beeps", which means the remote control is turned off.





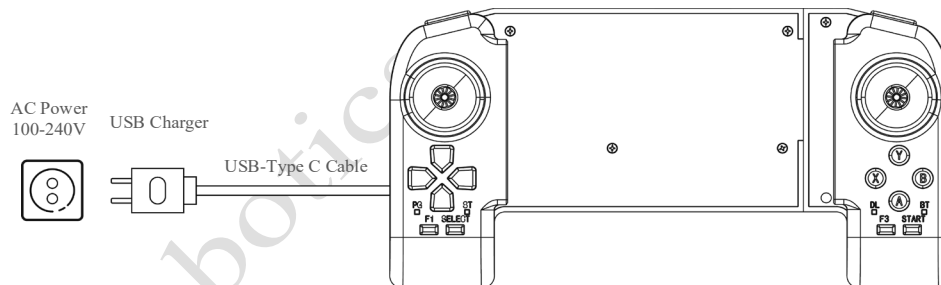











Handheld Remote Control Charging

When the handheld remote control battery indicator shows low power, the handheld remote control should be connected to the charger, as shown in the figure below:



- We recommend you to use a 5V/1A USB charger which meets FCC/CE standard.
- Ensure that handheld remote control is switched off before charging it.
- The power indicator light will flash at 1Hz (1 second/time) in charging status and indicate the current power level.
- When the power indicator light is all off it means the battery pack is full, please remove the charger to finish charging.

Charging Indicator Light

LED1	LED2	LED3	LED4	Current Battery
				0%-25%
				25%-50%
				50%-75%
				75%-100%
				Full Charged

Handheld Remote Control Basic Operation

For the first time to use handheld remote control, you need to bind it on Unitree Go App, [Settings] -> [Remote Control Settings] - turn on the remote control switch, enter the corresponding remote control code, and then you can bind it with the digital transmission module on the robot dog.

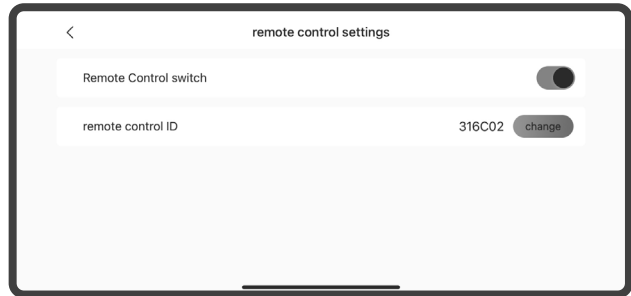
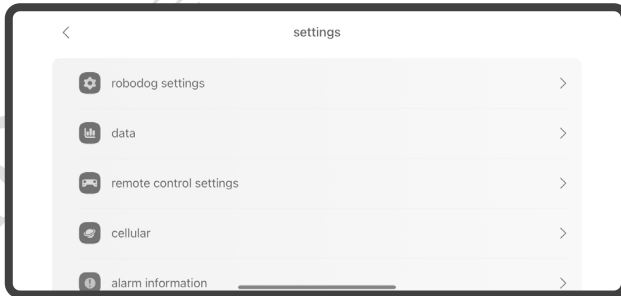

The digital signal lights on the left side of the two-handed remote control are all on, which means that the connection is successful. Then you can use the remote control to control the robot dog to complete the corresponding action. When the handheld remote control is used to control Go2, the control mode of the rocker is divided into standing control and walking control.

Standing control

Left rocker

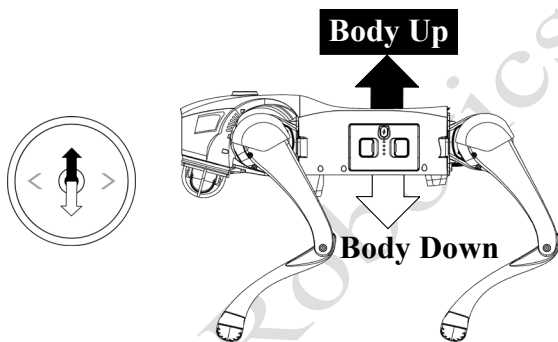

Body Rotates Right

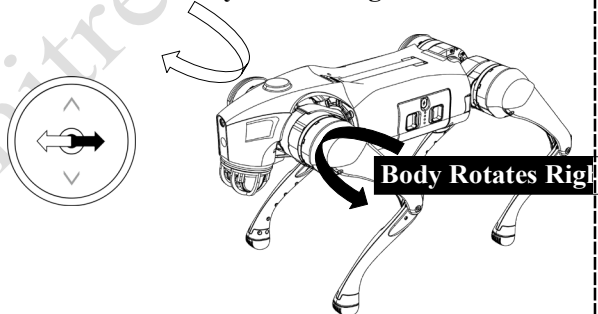

Right rocker

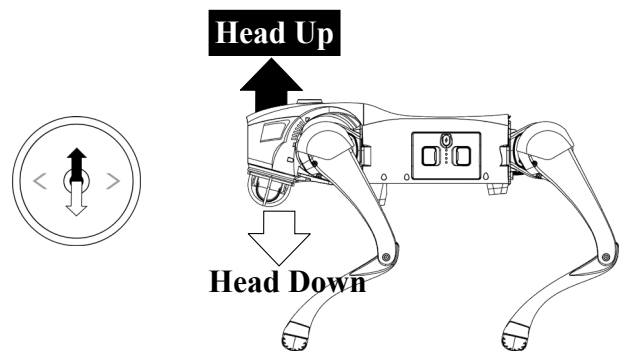

Look Left Look Right

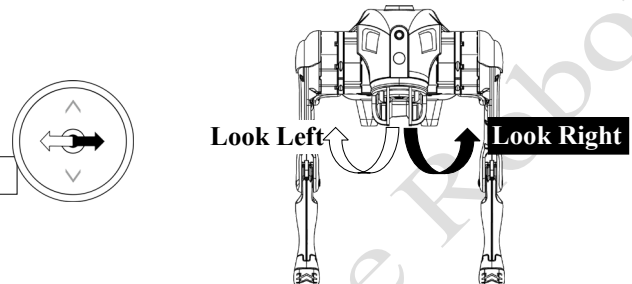

Walking Control

Left rocker

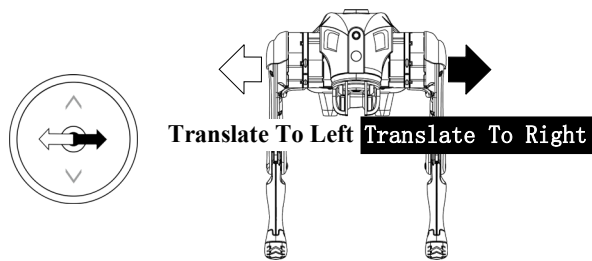
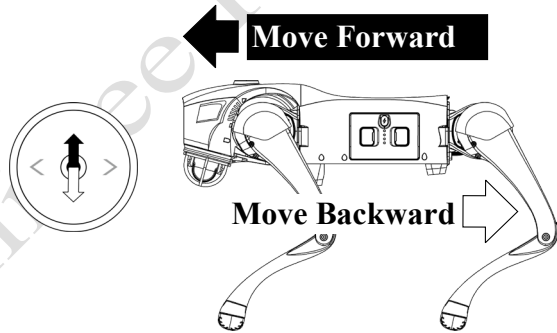

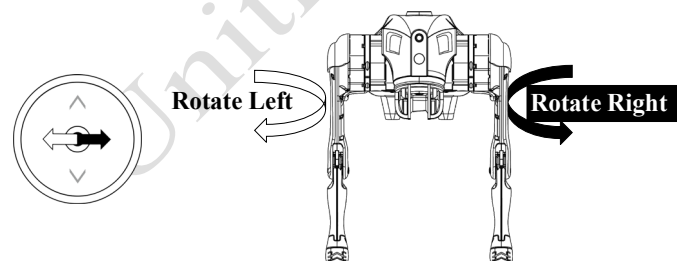
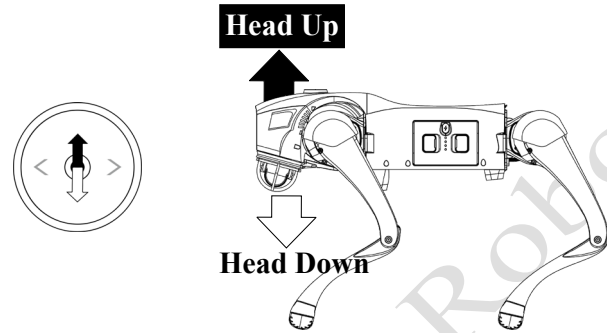

Right rocker

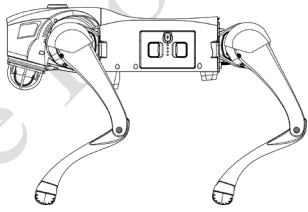
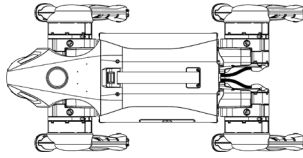
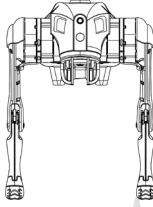
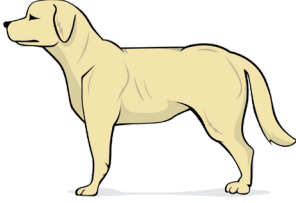
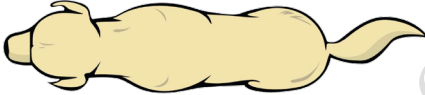

- Rocker back to center/neutral position: The rocker of the handle is in the middle position.
- Rocker amount: The deviation of the remote control rocker from the center of the rocker.
- Walls, doors, and other obstacles greatly weaken the signal between the robot and the remote control module. Please be sure to operate the robot in an open space.

Robot dog reference diagram:

	Side View	Top View	Front View
Robot			
Diagram			

Remote control command:

Button		Effect
Left Rocker	Push Forward/Backward	Move back or forth
	Push Left/Right	Sideways movement
Right Rocker	Push Forward/Backward	Head up or down
	Push Left/Right	Left or right turn
Switch Mode		
START		Get Unlocked
		Walking Mode
		Keep Walking Mode(double click)
SELECT		Make a pose
L2 (Long Press) + A (Click)		Locking Posture 1: lock joints when standing
		Locking Posture 2: Press again to go prone
L2 (Long Press) + B (Click)		Damping Mode (soft emergency stop)
L2 (Long Press) + START (Click)		Running Mode
L2(Long Press) + START (double Click)		Keeping Running Mode
RIGHT (Long Press) + START (Click)		Stair Climbing Mode 1: go upstairs forwards and downstairs backwards.
LEFT (Long Press) + START (Click)		Stair Climbing Mode 2: go downstairs forwards
L1 (Long Press) + SELECT (Click)		Endurance Mode

Customised Movements	
L2 (Long Press) + X (Click)	Back to stand up after falling down
R2 (Long Press) + A (Click)	Stretch
R2 (Long Press) + B (Click)	Shake hands
R2 (Long Press) + Y (Click)	Cheer
R1 (Long Press) + X (Click)	Punch
R1 (Long Press)+ A (Click)	Jump Forward
R1 (Long Press)+ B (Click)	Sit down
L1 (Long Press)+ A (Click)	Dance 1
L1 (Long Press) + B (Click)	Dance 2
Function	
X (Click)	Avoidance on (Default)
Y (Long Press for 3s)	Avoidance off
L2 (Click) + SELECT (Click)	Searchlight Switch - Default Off
Arrow keys left and right	Light switch-default green
Parameter settings	
L1 +Arrow keys up/down	Adjust leg lift height
Arrow keys up and down	Adjust body height



Please visit Unitree Go App to trigger more athletic modes!

- a) Moon walk: Can only be triggered by the App, not supported by handheld remote control.
- b) Side Step Mode: Can only be triggered by the App, not supported by handheld remote control.
- c) Cross step mode: Can only be triggered by the App, not supported by handheld remote control.
- d) Parallel leg running mode: Can only be triggered by the App, not supported by handheld remote control.

Generation ROBOTS

Brand of the group **NGX** ROBOTICS

Official Distributor

gr@generationrobots.com

+33 5 56 39 37 05

www.generationrobots.com

