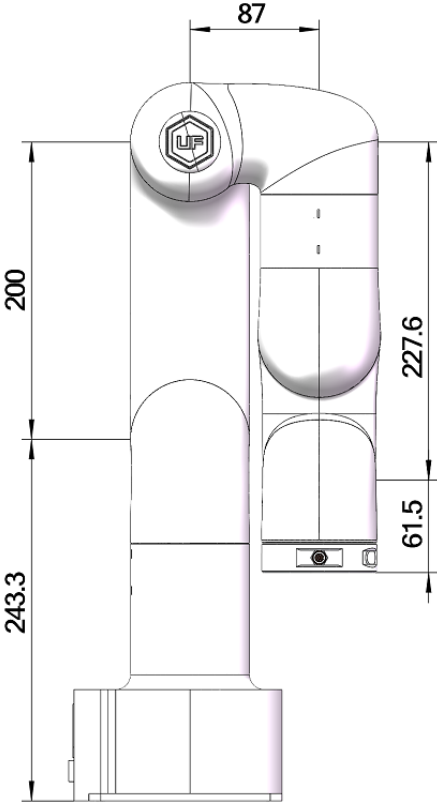
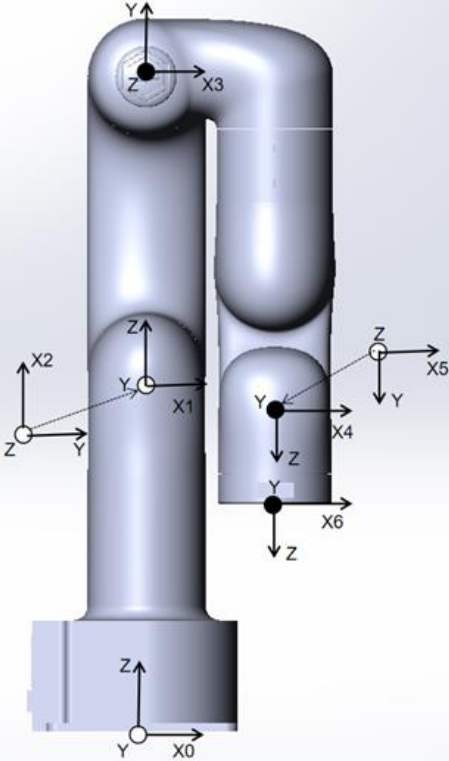

Kinematic and Dynamic Parameters of UFACTORY Lite 6

(1) Modified D-H Parameters:

Size Parameters: (unit:mm)	Joint Coordinate Definition
	

Kinematics	theta offset (deg)	d (mm)	alpha (deg)	a (mm)
Joint1	0	243.3	0	0
Joint2	-90	0	-90	0
Joint3	-90	0	180	200
Joint4	0	227.6	90	87
Joint5	0	0	90	0
Joint6	0	61.5	-90	0

(2) Standard D-H Parameters:

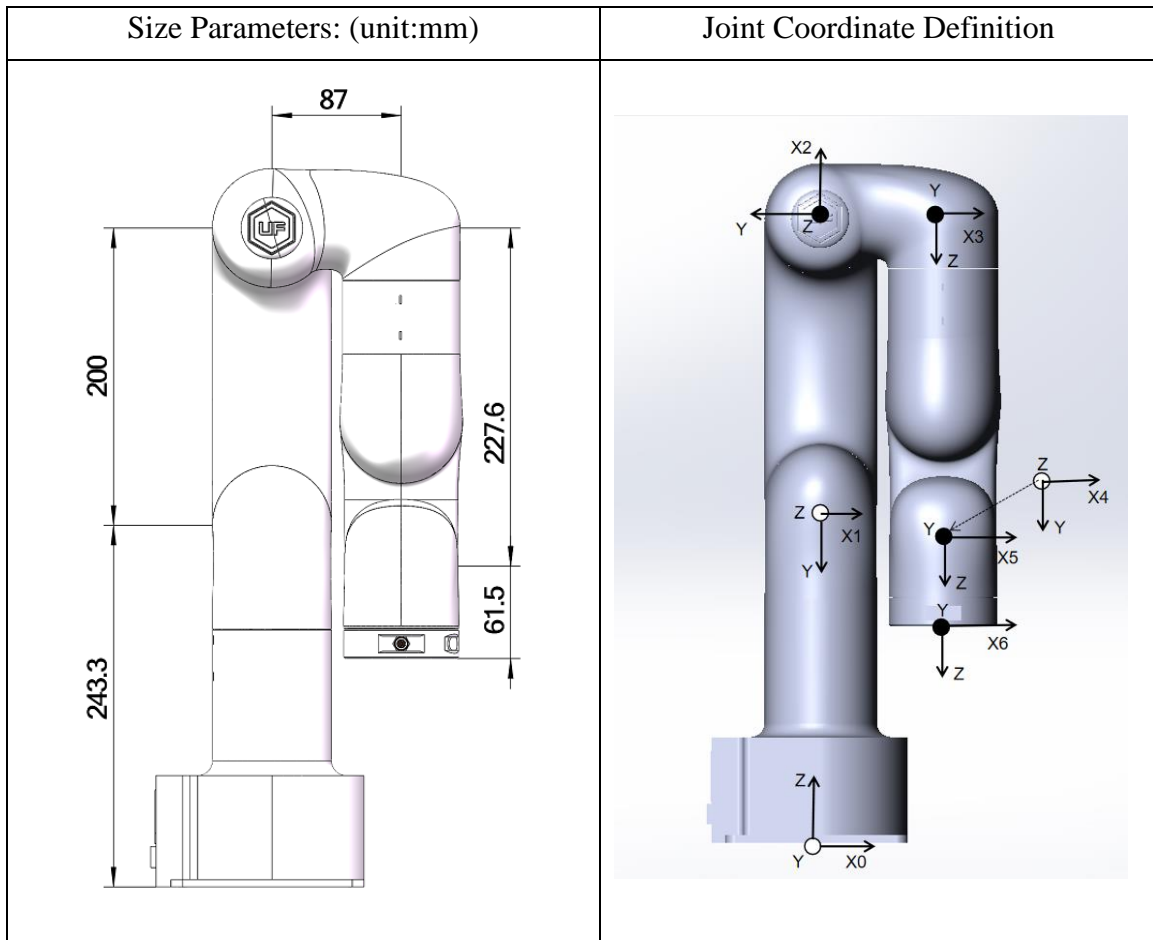

Kinematics	theta offset (deg)	d (mm)	alpha (deg)	a (mm)
Joint1	0	243.3	-90	0
Joint2	-90	0	180	200
Joint3	-90	0	90	87
Joint4	0	227.6	90	0
Joint5	0	0	-90	0
Joint6	0	61.5	0	0

(3) Mass Parameters:

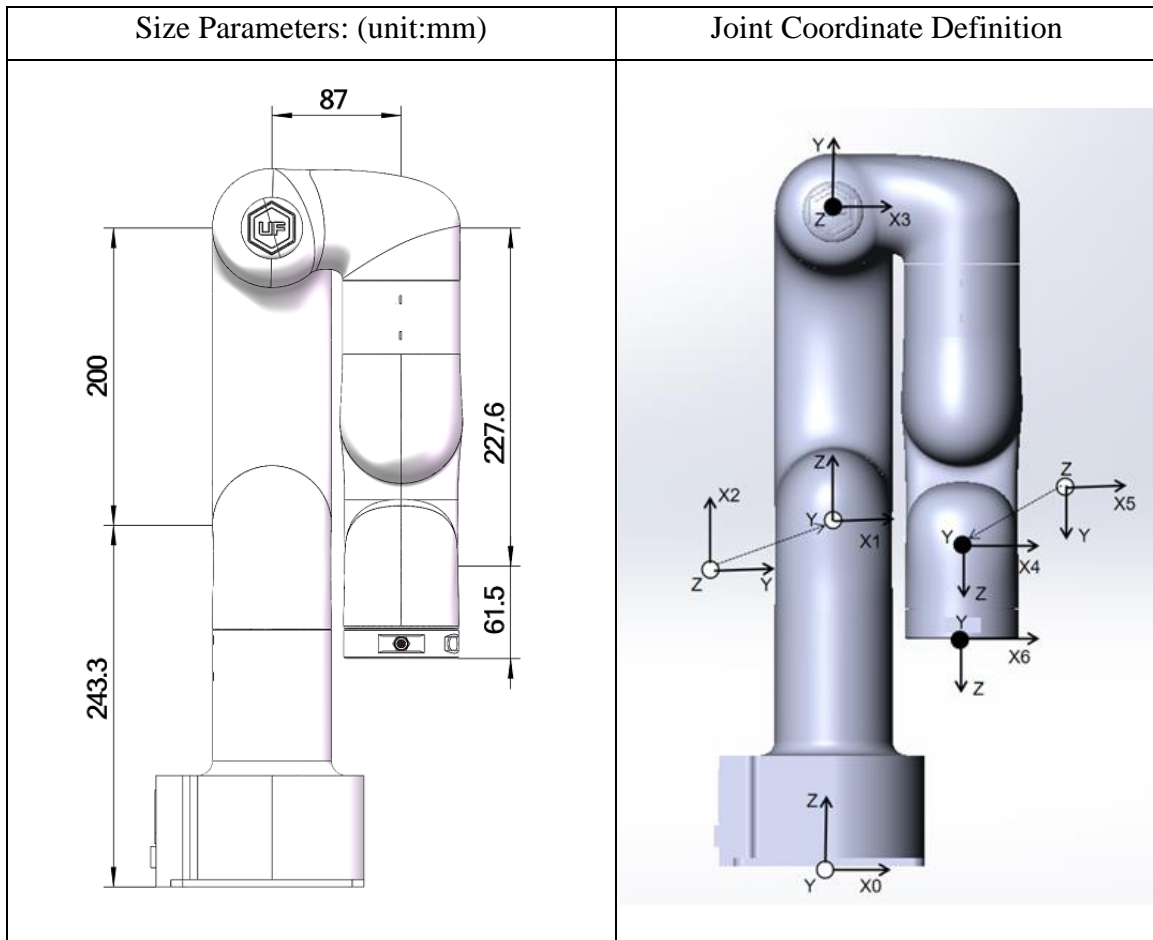

Dynamics	Mass(kg)	Center of Mass(mm)
Link1	1.411	[-0.36, 41.95, -2.5]
Link2	1.34	[179.0, 0.0, 58.4]
Link3	0.953	[72.0, -35.7, -1.0]
Link4	1.284	[-2.0, -28.5, -81.3]
Link5	0.804	[0.0, 10.0, 1.9]
Link6	0.13	[0.0, -1.94, -10.2]

Generation ROBOTS

Brand of the group **NGX** ROBOTICS

Official Distributor

gr@generationrobots.com

+33 5 56 39 37 05

www.generationrobots.com

