



DOC#:01.13.001700

# **X4PRO DATA SHEET**

[www.ydlidar.com](http://www.ydlidar.com)

Shenzhen EAI Technology Co.,Ltd.

# CONTENTS

<b>1 OVERVIEW</b> .....	<b>1</b>
<b>1.1 Product Features</b> .....	<b>1</b>
<b>1.2 Applications</b> .....	<b>1</b>
<b>1.3 Installation and Dimensions</b> .....	<b>1</b>
<b>2 SPECIFICATIONS</b> .....	<b>2</b>
<b>2.1 Performance Parameter</b> .....	<b>2</b>
<b>2.2 Electrical Parameter</b> .....	<b>2</b>
<b>2.3 Interface Definition</b> .....	<b>2</b>
<b>2.4 Data Communication</b> .....	<b>3</b>
<b>2.5 Motor Control</b> .....	<b>3</b>
<b>2.6 Optical Characteristics</b> .....	<b>4</b>
<b>2.7 Polar Coordinate System Definition</b> .....	<b>4</b>
<b>2.8 Others</b> .....	<b>5</b>
<b>3 REVISION</b> .....	<b>6</b>

# 1 OVERVIEW

YDLIDAR X4PRO is a 360 degrees two-dimensional rangefinder (hereinafter referred to as X4PRO) developed by EAI team. Based on the principle of triangulation, it is equipped with related optics, electricity, and algorithm design to achieve high-frequency and high- accuracy distance measurement. The mechanical structure rotates 360 degrees to continuously output the angle information as well as the point cloud data of the scanning environment while ranging.

## 1.1 Product Features

- 360 degrees omnidirectional scanning ranging distance measurement
- Small distance error, stable performance and high accuracy
- Wide ranging distance
- Strong resistance to ambient light interference
- Low power consumption, small size and long service life
- Laser power meets Class I laser safety standards
- Adjustable motor speed, scanning frequency is 6~12Hz
- High-speed ranging, ranging frequency up to 5kHz

## 1.2 Applications

- Robot navigation and obstacle avoidance
- Robot ROS teaching and research
- Regional security
- Environmental scanning and 3D reconstruction
- Navigation and obstacle avoidance of robot vacuum cleaner/ROS Learning robot

## 1.3 Installation and Dimensions

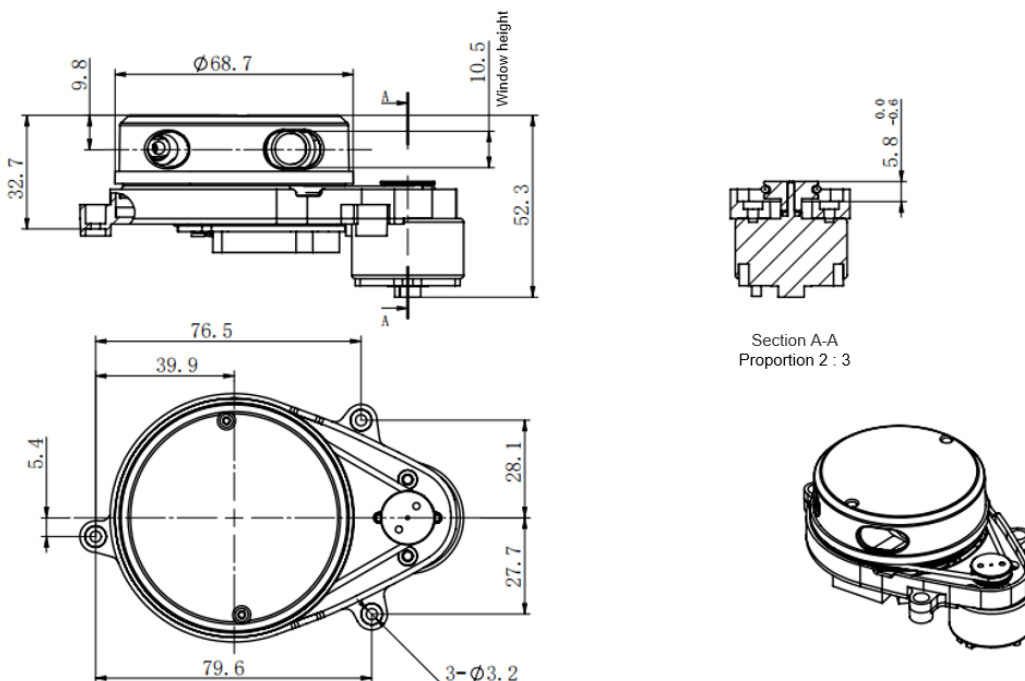

FIG 1 YDLIDAR X4PRO MECHANICAL DIMENSIONS

## 2 SPECIFICATIONS

### 2.1 Performance Parameter

**CHART 1 YDLIDAR X4PRO PERFORMANCE PARAMETER**

Item	Min	Typical	Max	Unit	Remarks
Ranging frequency	/	5000	/	Hz	5000 times per second
Scanning frequency	6	/	12	Hz	PWM or voltage speed regulation
Ranging distance	0.12	/	10	m	Indoor environment with 80% Reflectivity
Field of view	/	0-360	/	Deg	/
Absolute error	/	2	/	cm	Distance≤1m
Relative error	/	3.5%	/	/	1m<Distance≤6m
Tilt angle	0.25	1	1.75	Deg	/
Angle resolution	0.43 (frequency@6 Hz)	0.50 (frequency@7 Hz)	0.86 (frequency@12Hz)	Deg	Different motor frequency
Service life	/	1500	/	h	/

Note 1: The measurement range and relative accuracy above are the factory FQC standard value based on 80% reflectivity object.

Note 2: The relative error value indicates the accuracy of the Lidar measurement. Relative error (mean value) = (average measured distance-actual distance)/actual distance \*100%, sample size: 100pcs.

Note 3: Lidar is a precision device. Please avoid using Lidar under high or low temperature or strong vibration situation, which might cause an exceeded relative error.

### 2.2 Electrical Parameter

**CHART 2 YDLIDAR X4PRO ELECTRICAL PARAMETER**

Item	Min	Typical	Max	Unit	Remarks
Supply voltage	4.8	5	5.2	V	Excessive voltage might damage the Lidar while low voltage could affect normal performance
Starting current	/	800	1000	mV	instantaneous current, device needs higher current at startup
Working current	/	330	380	mA	Normal working current, at low temperature, the rotational resistance of the lidar increases, and the current will rise

### 2.3 Interface Definition

X4PRO provides a PH2.0-8P receptacle interface with functional interfaces for system power, data communication and motor control.

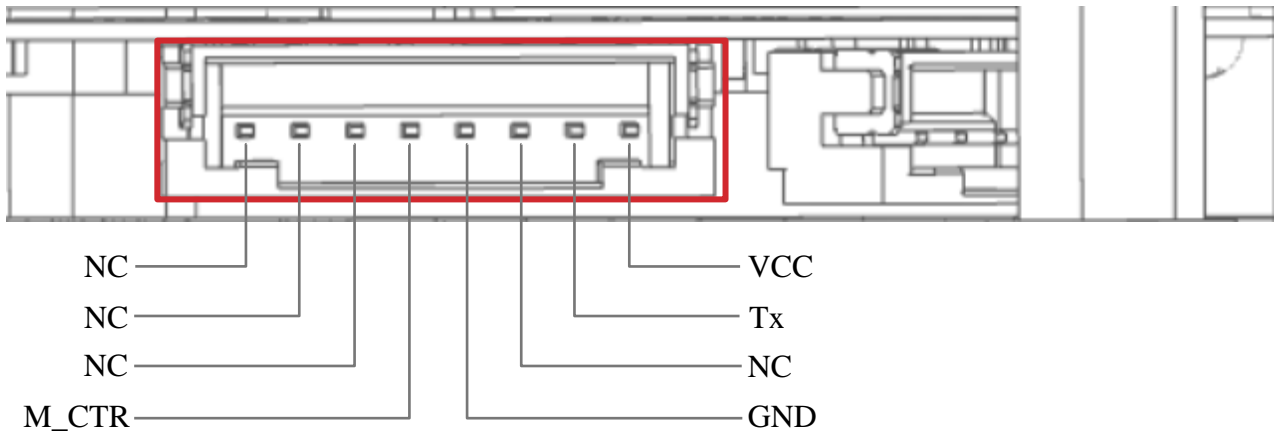

FIG 2 YDLIDAR X4PRO INTERFACES

### CHART 3 YDLIDAR X4PRO INTERFACE DEFINITION

Pin	Type	Description	Defaults	Range	Remarks
VCC	Power supply	Power supply voltage positive	5V	4.8V-5.2V	/
Tx	Output	System serial port output	/	/	Data stream: LiDAR→Peripherals
GND	Power supply	Power supply voltage negative	0V	0V	/
M_CTR	Input	Motor speed control end	2.15V	0V-3.3V	PWM speed control
NC	/	Reserved pin	/	/	/

## 2.4 Data Communication

X4PRO uses a 3.3V serial port (UART) for duplex communication, and only supports one-way communication (Tx) for data downlink. The user can connect the external system and the product through the physical interface on the product, and communicate in accordance with the system communication protocol to obtain the scanned point cloud in real time. Its communication parameters are as follows:

### CHART 4 YDLIDAR X4PRO SERIAL PORT SPECIFICATION

Item	Min	Typical	Max	Unit	Remarks
Baud rate	/	128000	/	bps	8-bit data bit, 1 stop bit, no parity
High signal level	2.4	3.3	3.5	V	/
Low signal level	0	0.3	0.6	V	/

## 2.5 Motor Control

X4PRO is a motor driver with its own motor speed regulation function. M\_CTR is the motor speed control signal, which can be used for voltage speed regulation and PWM wave debugging. The lower the voltage/PWM duty cycle, the higher the motor speed. 0V / Maximum speed at 0% duty cycle.

For example: M\_CTR input voltage is 0V, the motor rotates at the highest speed.

Among them, the PWM signal of M\_CTR has the following requirements:

### CHART 5 YDLIDAR X4PRO MOTOR PWM SIGNAL SPECIFICATIONS

Item	Min	Typical	Max	Unit	Remarks
PWM frequency	/	10	/	KHz	PWM as a square wave signal
Duty	0	65%	100%	/	Smaller duty value, higher scan rate

## 2.6 Optical Characteristics

The infrared point pulse laser used in X4PRO meets FDA Class I laser safety standards. When the system is working, lasers and optical lenses complete the transmission and reception of laser signals to achieve high-frequency ranging. To ensure the system's ranging performance, please ensure that the laser and optical lens of the X4PRO are kept clean. The laser optical parameters are as follows:

### CHART 6 YDLIDAR X4PRO LASER OPTICAL PARAMETERS

Item	Min	Typical	Max	Unit	Remarks
Laser wavelength	775	793	800	nm	Infrared band
Laser power	/	3	5	mW	Average power value
FDA	 Class I				

## 2.7 Polar Coordinate System Definition

In order to facilitate secondary development, X4PRO defines a polar coordinate system internally. The polar coordinates of the system take the center of the rotating core of X4PRO as the pole. The specified angle is clockwise as positive, and the zero angle is located directly in front of the X4PRO motor. Due to individual differences, there is a deviation of plus or minus 3 degrees.

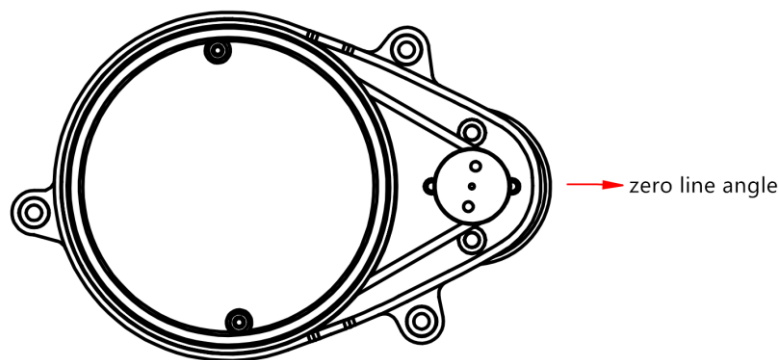

FIG 3 YDLIDAR X4PRO POLAR COORDINATE SYSTEM DEFINITION

## 2.8 Others

**CHART 7 YDLIDAR X4PRO OTHERS**

Item	Min	Typical	Max	Unit	Remarks
Operating temperature	0	20	40	°C	Long time working under high temperature will reduce the lifespan of the lidar sensor
Storage temperature	-10	20	60	°C	With package
Lighting environment	0	2000	40000	Lux	Reference only
weight	/	178	/	g	N.W.

### 3 REVISION

Date	Version	Content
2022-05-30	1.0	The 1st release