

NAO⁶

Datasheet

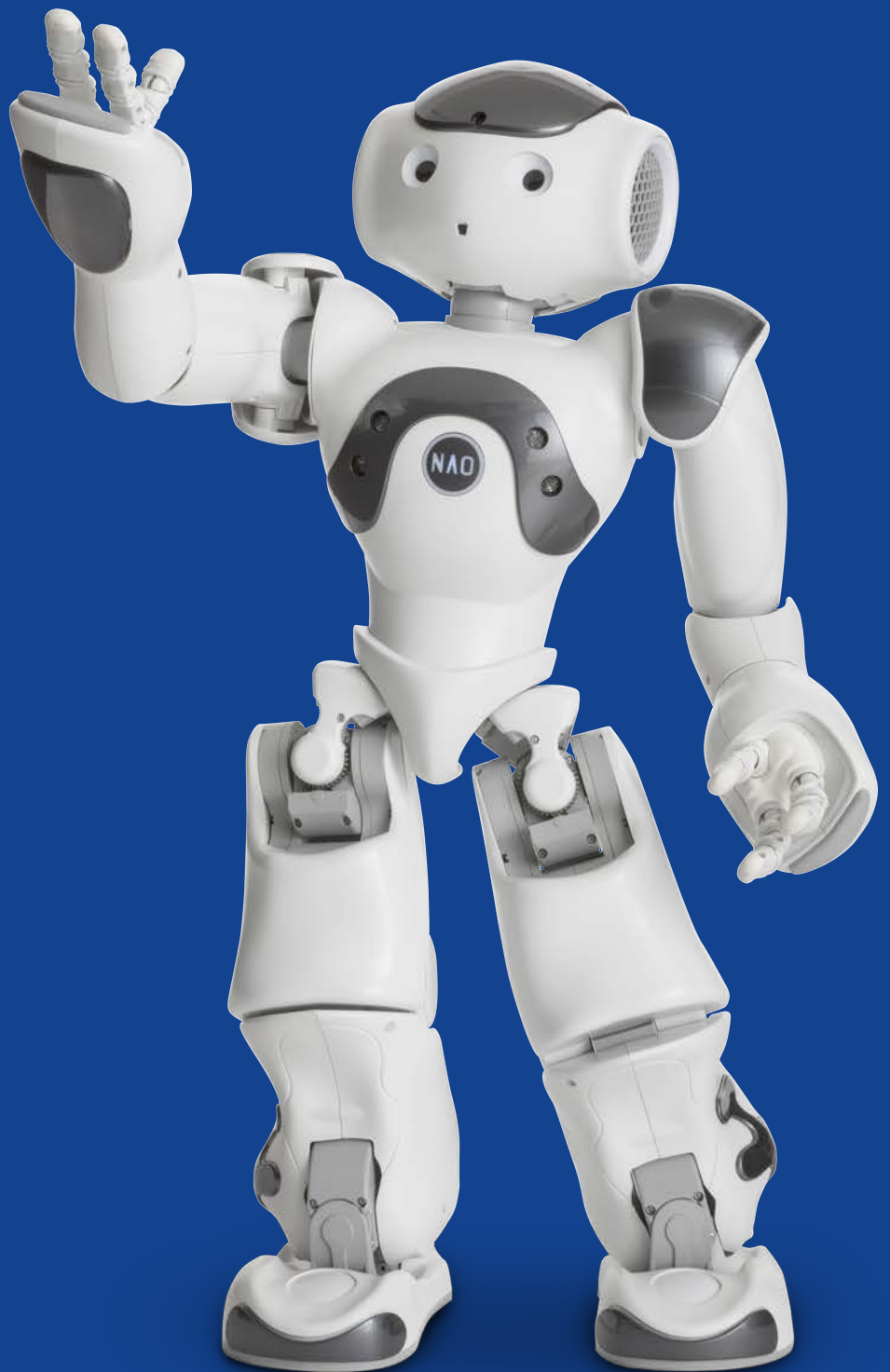

NAO⁶

MODEL: H25600

PHYSICAL CHARACTERISTICS

GENERAL

Size 574x311x275 mm / 22.6x12.2x10.8 in
(HxDxW)

Weight 5.48 kg / 12.08 lb

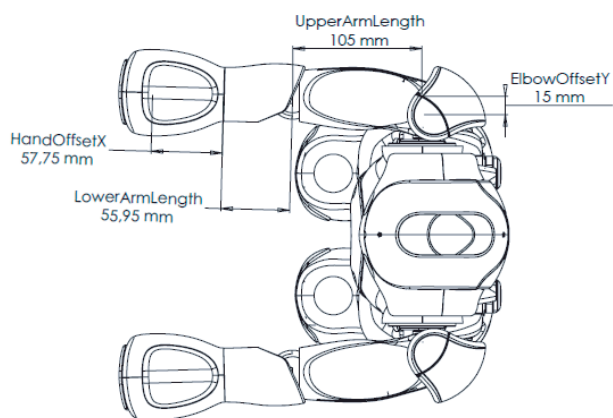
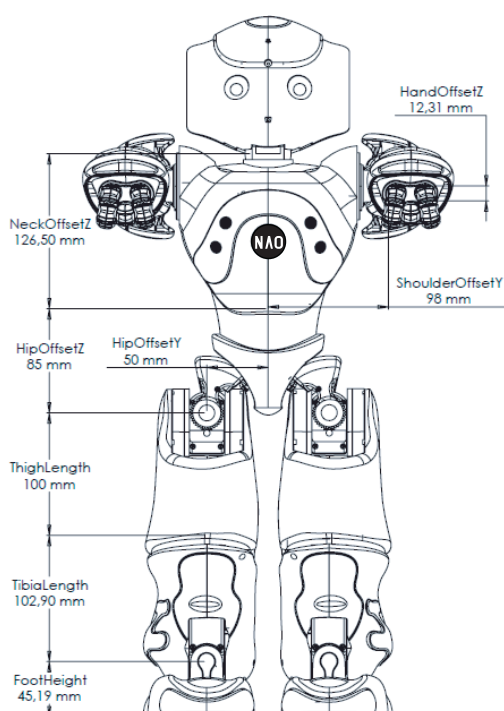

BRAIN SYSTEM

MOTHERBOARD

CPU	CPU processor	ATOM E3845
	Cache memory	2 MB
	Clock speed	1.91 GHz

RAM 4 GB DDR3

Flash memory 32 GB eMMC

HUMAN INTERACTION

LANGUAGES

Text to speech & Automatic speech Recognition Czech, Danish, Dutch, English, Finnish, French, German, Italian, Japanese, Greek, Polish, European Portuguese, Brazilian Portuguese, Spanish, Swedish, Russian, Turkish, Arabic, Brazilian, Standard Mandarin, Taiwanese Mandarin, Norwegian.

AUDIO

Loud Speakers	Left & Right
	Diameter 40 mm
	Impedance 4 Ω
	Audio power 87 dB +/- 3 dB
	Freq range up to ~20 kHz
	Input 2 W

Microphones	×4 omnidirectional on the head
	Sensitivity -12dBV/PA @1KHZ
	Frequency range 100HZ to 10KHZ

LEDS

Placement	Quantity	Description
Tactile Head	12	16 White levels
Eyes	2×8	RGB FullColor
Ears	2×10	16 Blue levels
Chest button	1	RGB FullColor
Feet	2x1	RGB FullColor

NAO⁶

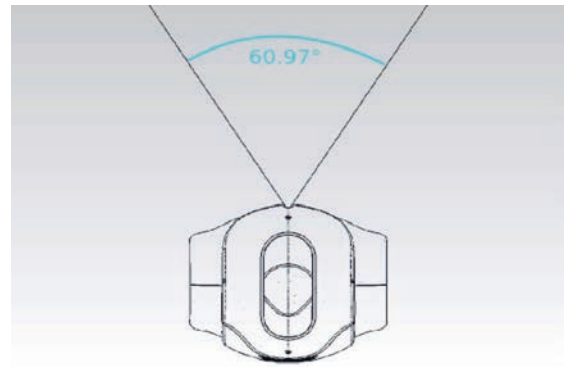
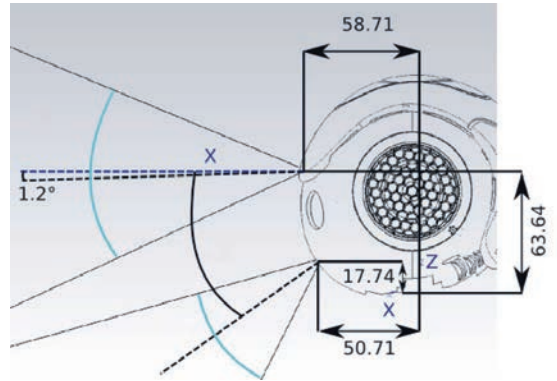
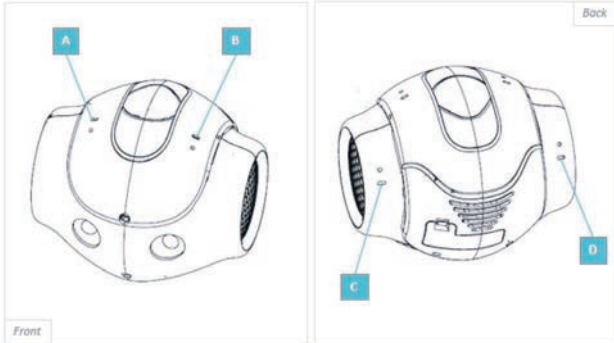

2D CAMERAS

Cameras	2 front of head	
Sensor model	OV5640	
Sensor type	SoC - CMOS Image Sensor	
Imaging array	Resolution	5 MP
	Size	1/4 in
	Active Pixels (H×V)	2592 x 1944
Sensitivity	Pixel size	1.4 x 1.4 μm
	Dynamic range	68 dB @8x gain
	Signal/Noise ratio (max)	36 dB
	Responsivity	600 mV/lux-sec
Output	Camera output	640 x 480 @30 fps
	Data Format	YUY & RGB
	Shutter type	Rolling Shutter/ frame exposure
View	Field of view	67.4° DFOV (56.3° HFOV, 43.7° VFOV)
	Focus range	10 cm ~ ∞ ≈ 4 in - ∞
	Focus type	Auto focus

FRAMERATES

Resolution	Top Camera	Bottom Camera
320x240 px	@15, 30 fps	@15, 30 fps
640x480 px	@15, 30 fps	@15, 30 fps
1280x960 px	@15, 30 fps	@10, 15 fps
1920x1080 px	@15, 30 fps	-
2560x1920 px	@15 fps	-

Note: The rate of the video stream will depend on the network and the video resolution chosen. All frame rates depend on the CPU usage. Values are measured with a CPU fully dedicated to image gathering.

ENVIRONMENT SENSORS

INERTIAL UNIT

Gyrometer	1	
	Axis	3
	Precision	5%
	Angular speed	500°/s approx.
IMU	1	
	Axis	3
	Precision	10%
	Angular speed	2 g approx.

NAO⁶

SONAR

Transmitters	2 on front
Receivers	2 on front
Frequency	40 kHz
Resolution	1 cm @50 cm
Detection Range	0.20 m to 0.80 m
Effective Cone	60°

BUTTONS & SENSORS

Chest Button	✓
Foot Bumper	✓
Tactile Head	✓
Tactile Hand	✓

ENERGY

ROBOT BATTERY

Battery	Type	Lithium-Ion
	Nominal voltage/capacity	21.6 V / 2.9 Ah
	Max charge voltage	25.2 V
	Recommended charge current	1.8 A
	Max charge / discharge current	2.1 A / 2.0 A
	Energy	62.5 Wh
	Charging duration	90 min
	Run time	60 min (Active use) 90 min (Normal use)

FORCE SENSITIVE RESISTORS (FSR)

Range	0 to 25 N
Location	4 in each foot
Sensitivity	40 g approx.

BATTERY CHARGER

Input	100 to 240 VAC – 50/60 Hz – Max 1.2 A
Output	25.2 VDC – 2 A

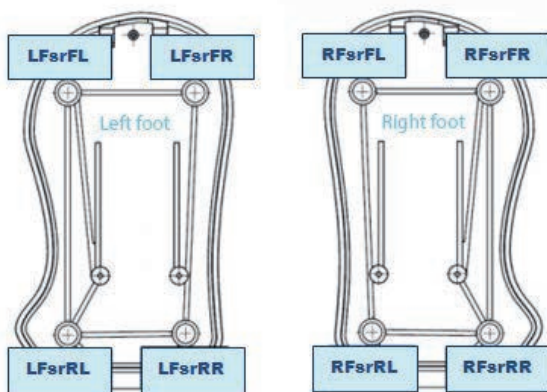
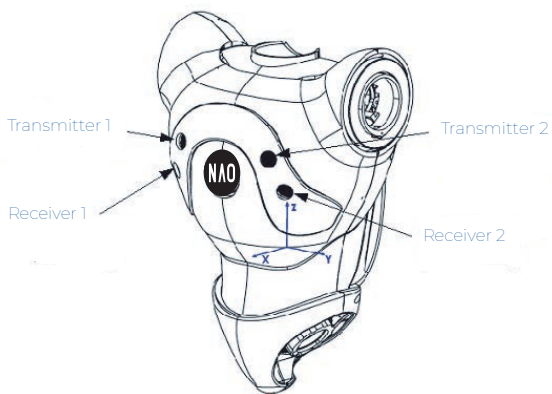

MOTION

DEGREES OF FREEDOM

Head	2
Arm (in each)	5
Pelvis	1
Leg (in each)	5
Hand (in each)	1

MOTOR SPECIFICATIONS

Motor type Brush DC Coreless

POSITION OF MOTORS

		Gear Ratio	Motor type
Head joints	HeadYaw	150.27	3
	HeadPitch	173.22	3
Arm joints	ShoulderPitch	150.27	4
	ShoulderRoll	173.22	3
	ElbowYaw	150.27	3
	ElbowRoll	173.22	3
Arm joints	WristYaw	50.61	2
	Hand/ Fingers	36.24	2
Leg joints	HipYawPitch	201.3	1
	HipRoll	201.3	1
	HipPitch	130.85	5
	KneePitch	130.85	5
	AnklePitch	130.85	5
	AnkleRoll	201.3	1

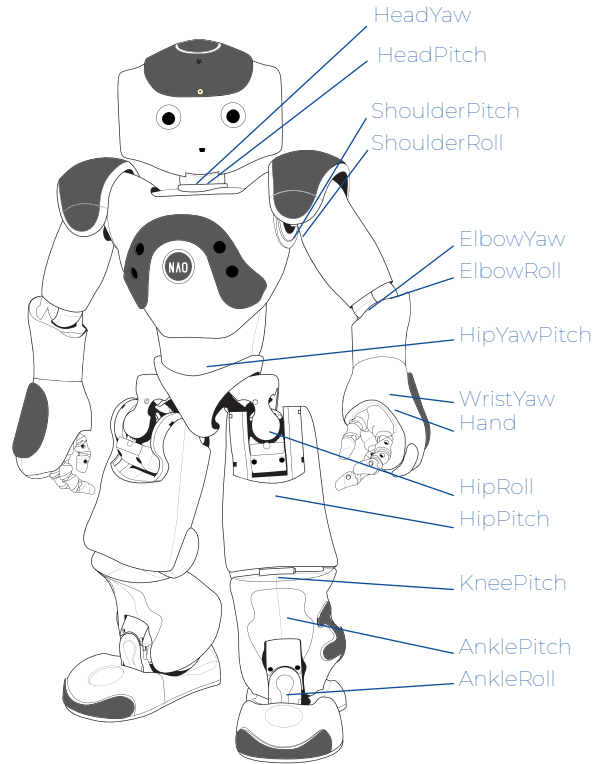

For details of type and gear ratio, see below.

MOTOR TYPE

	Motor type 1	Motor type 2	Motor type 3	Motor type 4	Motor type 5
Make	22NT82213P	17N88208E	16GT83210E	DCX 16S	22NT Z20
No load speed (rpm)	8700 ±10%	8400 ±12%	10700 ±10%	11400 ±10%	8700 ±10%
Stall torque (mNm)	65 ±8%	9.4 ±8%	14.3 ±8%	22.4 ±10%	65 ±10%
Continuous torque (mNm)	17.8 max	4.9 max	6.2 max	2.6 max	17.8 max

JOINT MOVEMENT ENCODERS

MRE 36
(Magnetic Rotary Encoder) Using hall effect sensor technology
Precision: 12 bits / 0.1°

NAO⁶

CONNECTIVITY

CONNECTION

Ethernet 1×RJ45 - 10/100/1000 BASE T

WIFI IEEE 802.11a/b/g/n

WPAN IEEE 802.15.1 (Bluetooth) 4.0 (LE)

SOFTWARE

Open Nao Embedded GNU/Linux
Distribution based on Gentoo

Architecture 86

Programming Embedded: C++ / Python
Remote: Java

Generation ROBOTS

Brand of **NGX** ROBOTICS



+33 (0)5 56 39 37 05



contact@generationrobots.com



1 rue Pierre-Georges Latécoère 33700 Mérignac, France

www.generationrobots.com

