

FRANKA HAND

Product Manual

TRANSLATION FROM THE ORIGINAL PRODUCT MANUAL

© Copyright 2024
Franka Robotics GmbH
Frei-Otto-Straße 20
80797 Munich
Germany

This document and extracts of it may only be reproduced or made available to third parties with the explicit authorization of Franka Robotics GmbH.

The content of this document has been carefully checked against compliance with the hardware and software described. However, discrepancies cannot entirely be ruled out, which is why we assume no liability for complete compliance.

In the interest of our customers, we reserve the right to undertake improvements and corrections to hardware, software, and documentation at any point in time without notice.

We are always grateful for your suggestions and comments at documentation@franka.de.

The German documentation is the ORIGINAL DOCUMENTATION. Other languages are translations of the original document.

Complementary documents to this Franka Hand product manual are:

- Quick Guide for Installation Franka Hand (Document number: R50040)

Document Name: Product Manual Franka Hand

Documentation number: R50010

Release Version: 1.1 (March 2024)

Change Log:

Release Version	Release Datum	Änderungen
1.0	Feb 2024	First Release Franka Robotics GmbH
1.1	March 2024	New content in chapter 1, Format corrections



Get your manual and additional supporting material in English and other languages at www.franka.de/documents.

TABLE OF CONTENTS

1	ABOUT FRANKA ROBOTICS	4
2	ABOUT FRANKA HAND	5
3	RIGHTS OF USE AND PROPERTY RIGHTS	6
3.1	General	6
3.2	Identification	6
4	SAFETY	7
4.1	Safety Instructions and General Indications	7
4.2	Notice of Liability	8
4.3	Intended Use	8
4.4	Misuse	8
4.5	General Possible Dangers and Safety Measures when Working with Robots	9
5	TECHNICAL SPECIFICATIONS	10
5.1	Mechanical Data	10
5.2	Technical drawings	11
6	SCOPE OF DELIVERY	15
7	INSTALLATION	16
7.1	Correct Site of Installation	16
7.2	Mounting the Franka Hand	17
7.3	Configuration	20
8	MAINTENANCE	25
8.1	Cleaning	25
8.2	Disposal	25
9	SERVICE AND SUPPORT	26
10	PRODUCT CONFORMITY	27
10.1	Declaration of Incorporation	27
10.2	Further Statements	28
10.3	Labeling	28
11	USING THE FRANKA HAND	29
12	CUSTOMIZING	31
13	TROUBLESHOOTING	32
14	ADDITIONAL INFORMATION	33
14.1	Extending the connector cable	33
15	TABLE OF FIGURES	34
16	INDEX	35

1 ABOUT FRANKA ROBOTICS



FRANKA ROBOTICS

Enabling industrial automation

Founded in 2016, Franka is a robotics platform company based in Munich with manufacturing facilities in Bavaria.

The Franka robot platform is extensively used in research and beyond, due to its unique control interface, human-like sense of touch technology, and large community of robotics and AI researchers and disruptors.

Since November 2023, Franka Robotics has been a part of Agile Robots AG, representing a powerful alliance of experts in the industry. Together, we strive to advance innovation in research and industrial automation shaping the future of robotics.

Introducing Franka World – a digital robotics platform

After redefining robotics and establishing a community, we launched a novel digital robotics platform to interconnect the digital world with the physical world.

Franka World allows community interaction between researchers, partners, customers, developers, suppliers, and robots. In addition, all users can easily gain integrated access to products and services and manage their entire robot fleets, independent of their physical location. Franka World also allows for easy robot deployment and updating.

We strive for a world where everyone can use a robot, and we can reach that by connecting the world. We treasure our community of robotics professionals, academics, and enthusiasts, from whom we learn every single day.

As members of the community ourselves, we commit to supporting each other and thriving together. Franka Robotics – a certified robotics platform with tactile intelligence.

2 ABOUT FRANKA HAND

This is Franka Hand

an electrical two-finger parallel gripper produced by Franka Robotics. No external cabling is needed. Communication and power supply for the Franka Hand is established via the flange connector of the Arm.

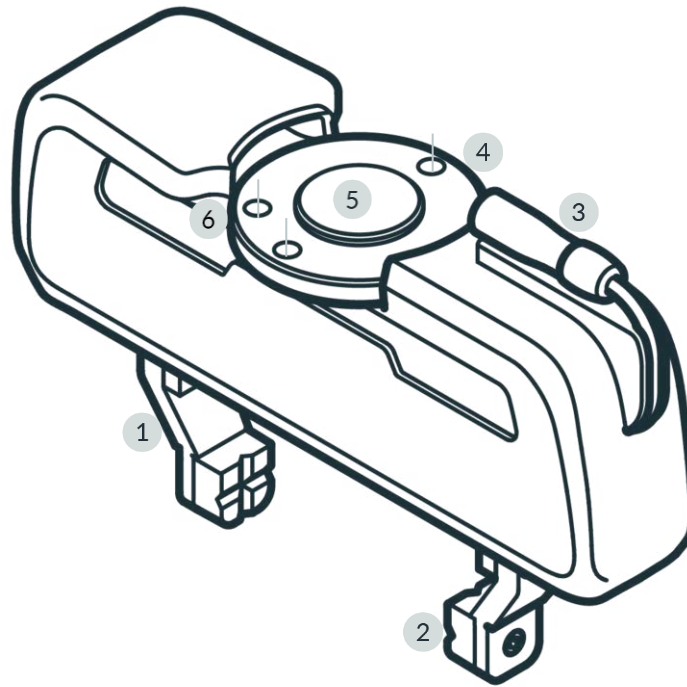

Figure 2.1: Overview Franka Hand

1	Finger	4	Screw holes
2	Fingertip	5	Flange to Arm
3	Plug	6	Hole for alignment pin

Fingertips	The fingertips can easily be changed and adapted to the objects to be grasped (e.g. using 3D-printed fingertips).
Fingers	The fingers can also be mounted in a rotated orientation in order to increase the span length of the gripper.
Plug	The plug is simply plugged into the X6 end effector connector port on the flange of the Arm.
Interface/flange	The interface/flange of Franka Hand is designed according to DIN ISO 9409-1-A50.

3 RIGHTS OF USE AND PROPERTY RIGHTS

3.1 General

Protected trademarks

In this product manual we refer to protected trademarks that are not designated explicitly as such in the continuing text. The absence of such indication may not imply that the corresponding product name is free of third-party rights. The following trademarks are protected trademarks:

- Franka and Franka Robotics are registered trademarks.

Trademark rights

The responsible person is not granted any rights or claims to the trademark, logo, or trade names of Franka Robotics.

Use of open-source codes

A complete list of all open-source licenses used by compatible Robots of Franka Robotics can be accessed via the settings menu of the Franka UI.

3.2 Identification

Removal of identification

Copyright notices, serial numbers, and any other kind of labelling serving to identify the product or operating software may not be removed or modified.

4 SAFETY

4.1 Safety Instructions and General Indications

Before installation, start-up, and operation of the device, carefully read this manual and any additional documentation related to it. Take note of the safety instructions as well as general indications.

Warning notices are posted as follows:

CAUTION

Type of hazard and potential consequences of hazard.
Evasive/avoidance actions to be taken.

Warning notices

The following warning notices are used in this manual:

DANGER

DANGER indicates a hazardous situation that, if not avoided, will result in death or serious injury.

WARNING

WARNING indicates a hazardous situation that, if not avoided, could result in death or serious injury.

CAUTION

CAUTION indicates a hazardous situation that, if not avoided, could result in minor or moderate injury.

NOTICE

NOTICE indicates information considered important but not hazard related.

SAFETY- INSTRUCTION

SAFETY INSTRUCTION indicates processes that need to be strictly observed.

Indications



Indicates where further information can be obtained.

4.2 Notice of Liability

Franka Hand has been developed according to the relevant quality standards. A hazard and risk assessment according to EN ISO 12100 has been carried out through the course of development and is the basis for Franka Hand and this manual.

The present document includes assembly instructions for compatible Franka Robotics robots as partly completed machinery. It contains descriptions of the conditions which must be met with a view to correct incorporation in the final machinery, so as not to compromise safety and health (e.g. Annex I of Machinery Directive 2006/42/EC).

4.3 Intended Use

Use the Franka Hand only in connection with compatible Robots of Franka Robotics systems and the associated intended use. The Franka Hand can be used for research and industrial use.

The end effector may be applied only in the ambient and operating conditions described in this document for the tasks of e.g., testing and inspection, Franka Handling, or mounting.

Franka Hand may only be used in sound technical condition, for its intended purpose and within the technical specifications and operating conditions, with awareness of safety and possible dangers.

The present Franka Hand end effector is intended exclusively for use as described in this manual.

For the normal and extended working conditions under which the Franka Hand should operate, see Technical Specifications.

4.4 Misuse

Misuse of the Franka Hand voids the manufacturer's warranty and liability. Any application different to the intended purpose is considered a misuse and is not permissible.

WARNING

Misuse may lead to danger to life and limb, impairments, damage to the robot, and other material assets. The manufacturer is not liable for damages caused by misuse.

Misuse is any use that deviates from the warnings, notices, and instructions in this manual, in particular, but not limited to, the following uses:

- Transportation of people and animals
- Transportation without original packaging
- Use in potentially explosive areas
- Use below ground
- Use in handling of radioactive objects
- Use outdoors
- Use as a medical product
- Use in the vicinity of children
- Handling of liquids
- Use outside of the specified operating limits

Modifications to the Franka Hand that are not explicitly permitted by Franka Robotics are not allowed and will lead to loss of warranty and liability claims. Not permitted modifications include, but are not limited to, the following:

- Any adaption of the mechanical structure
- Varnishing

- Enwrapping the robotic structure

It is prohibited to open the Franka Hand enclosure and other equipment.

Franka Robotics is not liable for damages caused by mounted, grasped or lost equipment or damages caused by misuse.

4.5 General Possible Dangers and Safety Measures when Working with Robots

An extensive but not definitive list of dangers that generally may be presented by a robot system can be found under EN ISO 10218-1:2011 ANNEX A.

Before putting the Franka Hand into use with a robot, an application-specific risk assessment (e.g., according to EN ISO 12100 and/or EN ISO 10218-2) must be performed by the integrator.

SEEPO ("Safe End Effector Power Off" safety function) may be configured in the robot accordingly. For more information, see chapter Safety Settings and Watchman in the relevant Franka Production product manual.

5 TECHNICAL SPECIFICATIONS

5.1 Mechanical Data

Description	Coordinate	Unit	Value
Outer dimension	width	[mm]	63
	length		205
	height		127
Weight		[g]	730
Center of mass of Franka Hand to end effector flange	X	[mm]	0
	Y		9,3
	Z		30,2
Grasping (continuous) force adjustable		[N]	30-70
Travel Range		[mm]	80
Travel Speed (per finger)		[mm/s]	50

Moment of Inertia [kgm²]

- *Franka Hand closed related to the end effector flange.*

$$\mathbf{I} = \begin{bmatrix} I_{xx} & I_{xy} & I_{xz} \\ I_{yx} & I_{yy} & I_{yz} \\ I_{zx} & I_{zy} & I_{zz} \end{bmatrix} = \begin{bmatrix} 0,0027 & 0 & 0 \\ 0 & 0,0011 & 0 \\ 0 & 0 & 0,0018 \end{bmatrix}$$

- *Franka Hand opened related to the end effector flange.*

$$\mathbf{I} = \begin{bmatrix} I_{xx} & I_{xy} & I_{xz} \\ I_{yx} & I_{yy} & I_{yz} \\ I_{zx} & I_{zy} & I_{zz} \end{bmatrix} = \begin{bmatrix} 0,003 & 0 & 0 \\ 0 & 0,0011 & 0 \\ 0 & 0 & 0,0021 \end{bmatrix}$$

Transformation matrix from end effector flange to Franka Hand (e.g., to center point of fingertips when closed, as illustrated in the figure below)

$${}^F T^{TCP} = \begin{bmatrix} R_{xx} & R_{xy} & R_{xz} & p_x \\ R_{yx} & R_{yy} & R_{yz} & p_y \\ R_{zx} & R_{zy} & R_{zz} & p_z \\ 0 & 0 & 0 & 1 \end{bmatrix} = \begin{bmatrix} 0.707 & 0.707 & 0 & 0 \\ -0.707 & 0.707 & 0 & 0 \\ 0 & 0 & 1 & 0.1034 \\ 0 & 0 & 0 & 1 \end{bmatrix}$$

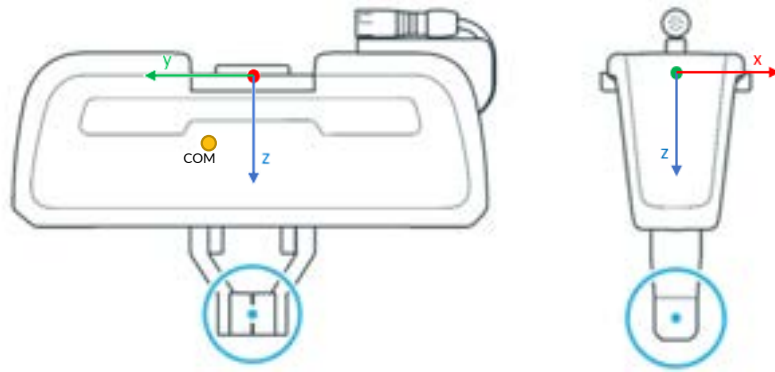

Figure 5.1: Coordinate system and centre of mass

5.2 Technical drawings

5.2.1 Outer dimensions

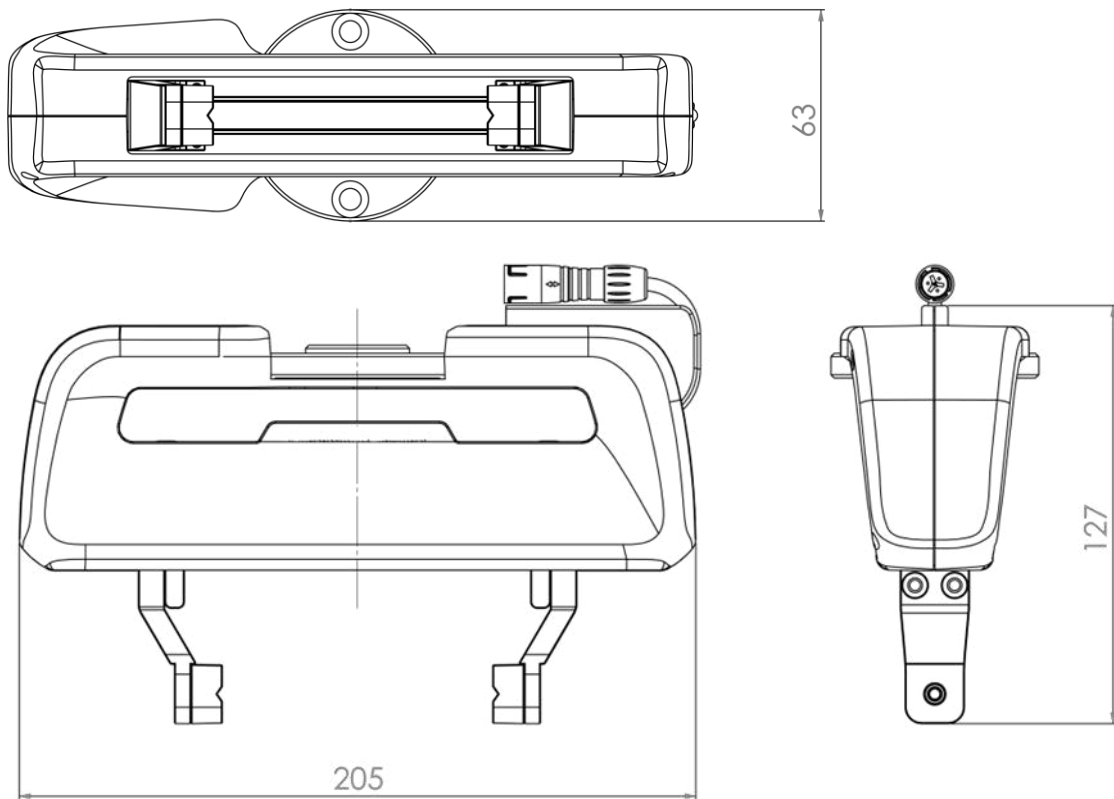

Figure 5.2: Outer dimensions [mm]

5.2.2 Dimensions of flange

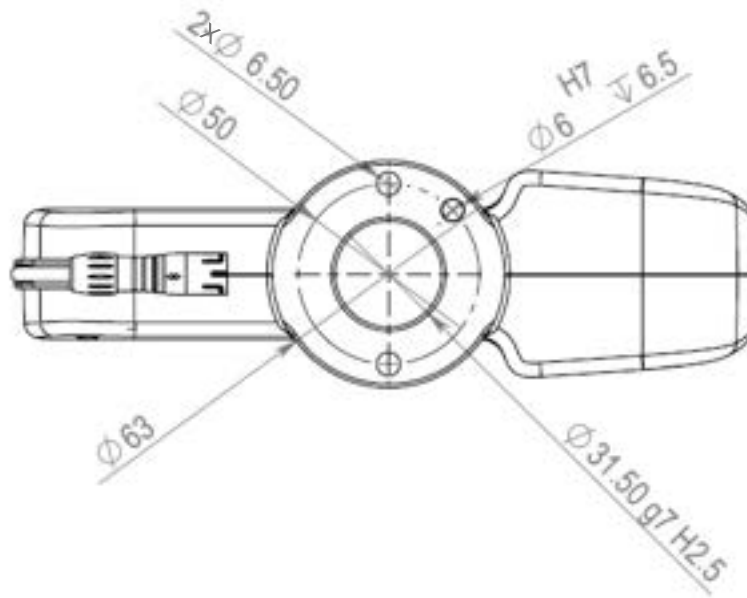

Figure 5.3: Dimensions of flange [mm]

5.2.3 Travel range

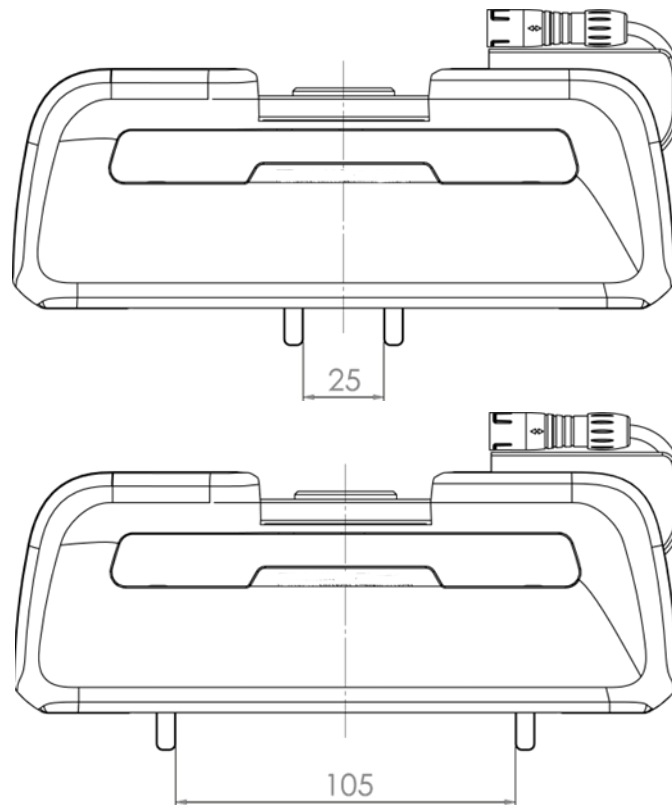

Figure 5.4: Travel range [mm]

5.2.4 Finger adaption Interface

- Recommended screws: 4x M4x12
- Tightening torque: 2.25 Nm

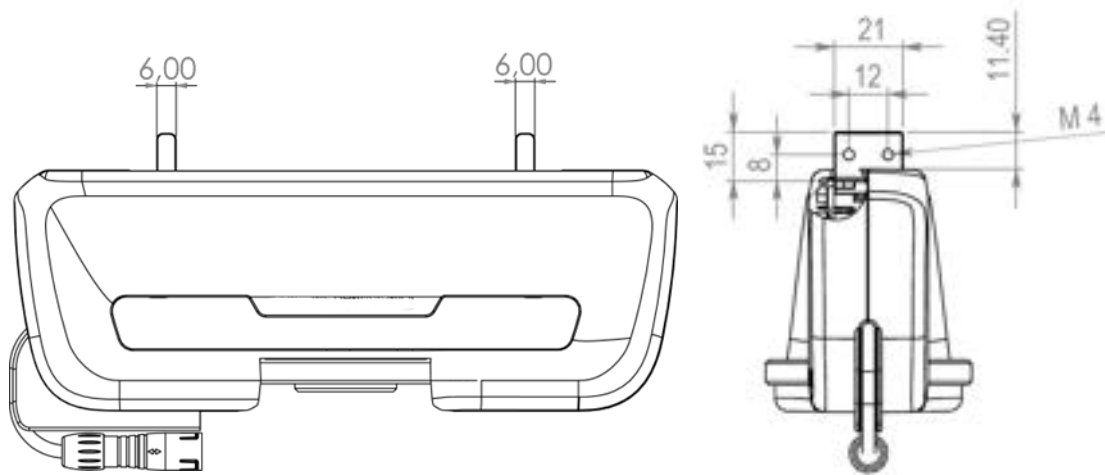

Figure 5.5: Finger adaption interface [mm]

In the scope of delivery of the Franka Hand there are standard fingertips which are suitable to be mounted to the fingers of the Franka Hand. Should you design and mount other fingers to the Franka Hand, the following needs to be noted:

Production standard

Carry out a risk assessment and implement the measures resulting from it.

Gripping of an object at a distance of the finger to the Franka Hand will lead to tilting loads. The Franka Hand is designed and tested for a finger length of 54 mm.

5.2.5 Fingertips interface

- Screws: 2x DELTA PT® 40x10 WN 5451
- Thread diameter: M4
- Tightening torque: 0.3 Nm

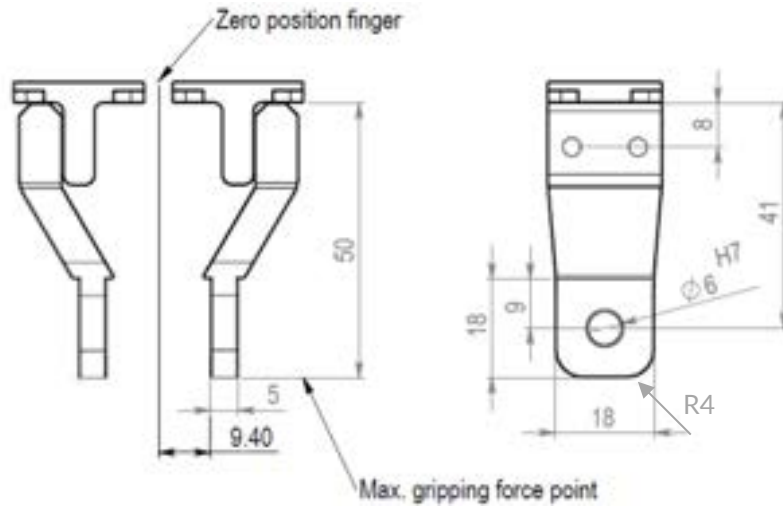

Figure 5.6: Fingertips interface [mm]

5.2.6 Fingertips

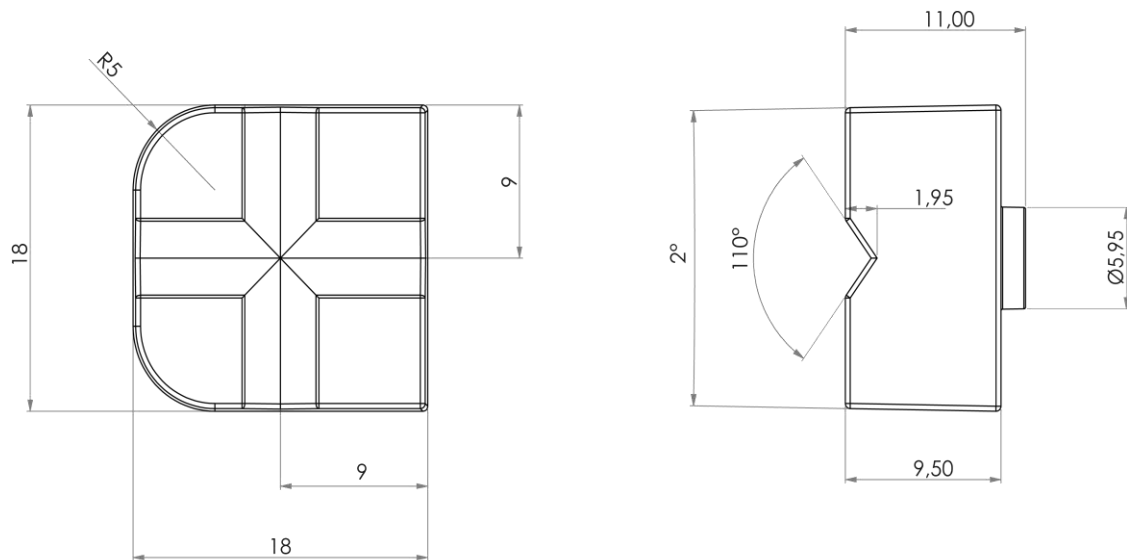

Figure 5.7: Dimensions fingertips [mm]

6 SCOPE OF DELIVERY

Scope of delivery and additionally required equipment

Main components:

- Franka Hand

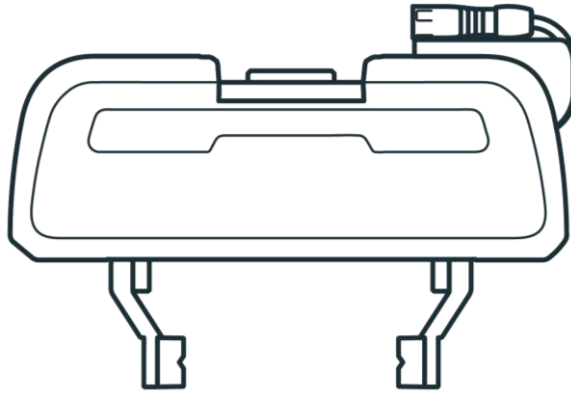

Figure 6.1: Franka Hand

Also included:

- 1 set of fingertips
- 2 x DIN7984 M6x12 ST 8.8 screws
- 1 x ISO2338B $\varnothing 6 \times 10$ h8 A2 cylindrical pin
- Quick Guide for Installation Franka Hand

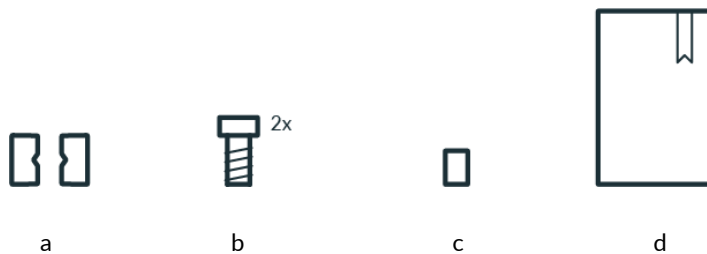

Figure 6.2: Additional material

Additional required equipment:

- Hex key size 4
- A compatible robot system of Franka Robotics

7 INSTALLATION

7.1 Correct Site of Installation

Ambient conditions

Site of installation

- Indoors, in enclosed buildings
- Not exposed to direct sunlight
- No vibrations
- External magnetic fields are allowed in the magnitude of the earth's magnetic field only

Type of installation

- Screwing connection to a compatible robot end effector flange

Protection class

- IP 20 (according to EN 60529:1991)

Ambient air

- Free from flammable substances (dust, gas, liquid)
- Free from aggressive media
- Free from corrosive substances
- Free from "flying parts"
- Free from spraying liquids
- Free from pressurized airstreams

Pollution degree

- Degree 2 (according to IEC 60664)

Only dry, non-conductive pollution occurs; occasionally temporary conductivity caused by condensation may occur.

Ambient temperature

- +15 °C to +25 °C (typical)
- +5 °C to + 45 °C (extended)
- -10 °C to + 60 °C (transport)
- +5 °C to + 25 °C (storage)

Relative air humidity

- 20 % - 80 %, non-condensing

Set-up altitude

- <= 2000 m above sea level

7.2 Mounting the Franka Hand

WARNING

Falling Franka Hand

Risk of severe injury, such as crushing to fingers, Franka Hands, upper body, head.

Ensure the Franka Hand is mounted correctly.

WARNING

Risk of electric shock

Risk of personal injury by electric shock.

Disconnect the Arm from the mains power supply before mounting the Franka Hand.

WARNING

Falling objects/tools

Objects or tools could fall at any time (e.g., due to loose couplings, malfunctions that can cause the Franka Hand to open or when a compatible robot of Franka Robotics is switched off, or the power to the robot system is cut) which could lead to injury to fingers, Franka Hands, toes, and feet.

- Take this into consideration while performing a hazard and risk assessment.
- Take also the SEEPO into account in the risk assessment because the Franka Hand will only be powered if brakes are open due to a configuration of the SEEPO

WARNING

Falling and/or flying tools from the robot

Tools that remain inserted in the robot may turn into projectiles during later motions of the Arm and lead to injuries.

Do not leave any tools inside the robot.

Precondition: The robot is switched off before mounting the Franka Hand.

Required material: 2x Srews (DIN 7984 M6x12 8.8)
1x Cylindrical pin (ISO2338B Ø6h8x10 A2)

Mounting

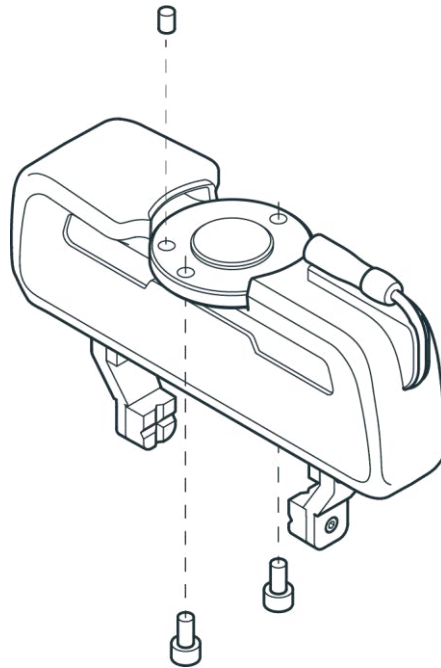

Figure 7.1: Mounting of Franka Hand

1. If desired, insert the cylindrical pin in the $\text{Ø}6\text{H}7$ fit of the flange of the Franka Hand. Should you not use the cylindrical pin, make sure that the side of the Franka Hand with the cable is aligned to the side of the flange where the connector is located.
2. Position the Franka Hand with its flange on the end effector flange on the Arm.
3. Attach the Franka Hand with two M6x12 DIN 7984 screws (do not use other types of screws) and use 5 Nm of fastening torque.
4. Insert the plug connector of the Franka Hand into the X6 connector on the flange of the Arm.

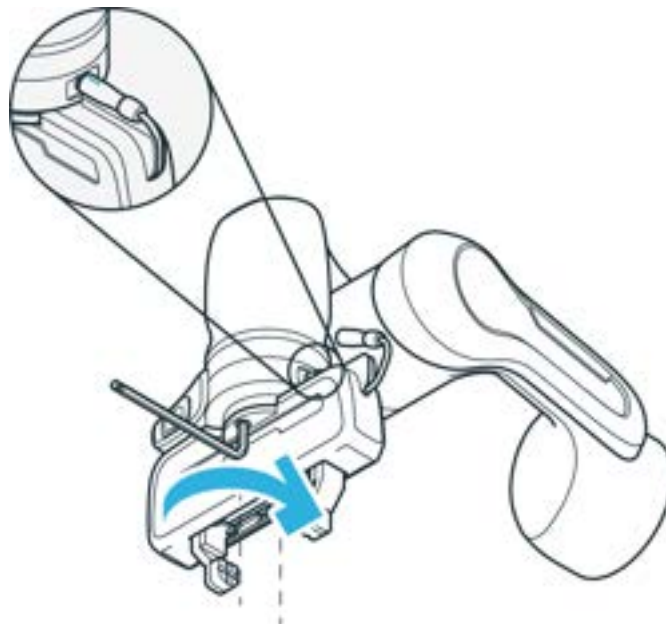

Figure 7.2: Electrical connection

NOTICE

Material damage to the Franka Hand

Using other screws and a higher torque than mentioned in the manual may lead to damage to the Franka Hand.

- To fix the Franka Hand, only use 2x M6x12 DIN 7984 screws.
- Only use 5 Nm of torque.

NOTICE

Material damage to the Franka Hand

Connecting or disconnecting live cables or connectors during operation may lead to damaging the Arm or the Franka Hand.

Do not connect or disconnect the Franka Hand while a compatible robot of Franka Robotics is not safely disconnected from the mains power supply.

NOTICE

Using the above-mentioned screws, the screw-in depth is 8 mm. This should never be exceeded!

7.3 Configuration

7.3.1 Mechanical Data

WARNING

Unexpected motions during guiding due to incorrectly configured end effectors

Incorrectly configured end effector mass and inertia may result in the gravitational forces not being fully compensated for. The resulting and unexpected behavior of the robot including end effector may lead to injuries such as crushing, tearing of skin, and puncturing.

- Always check the configuration of the end effector.
- When copying an already parametrized app or task to another compatible robot system of Franka Robotics, ensure that the end effector configuration is still identical to the original one.

When first starting compatible Franka robots – by means of the initial configuration – or at a later point in time by accessing the end effector settings, the Franka Hand can be selected from a dedicated dropdown menu.

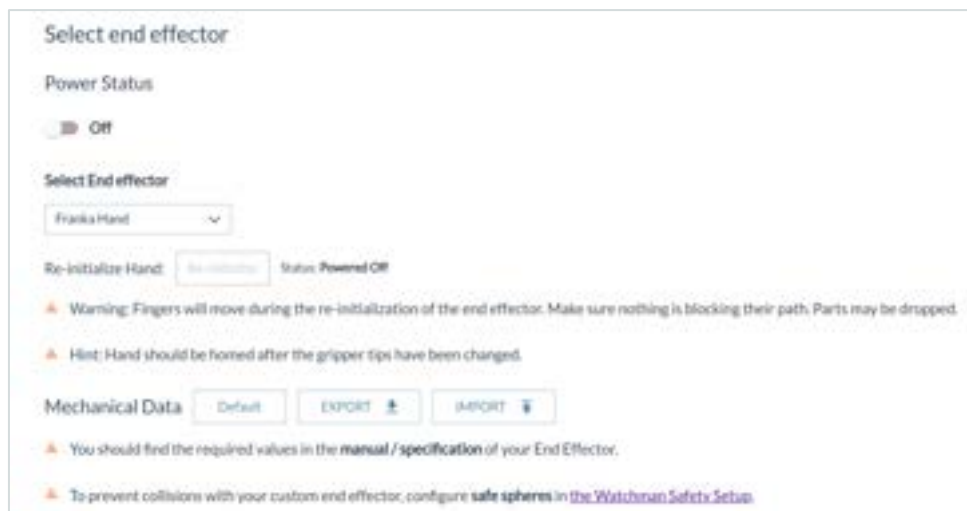

Figure 7.3: Screenshot Power Status

If you want to use another gripper or adjust the configuration of the Franka Hand, select “User Defined” from the drop-down menu and enter the corresponding values into the text fields.

INSTALLATION

The default settings of the Franka Hand are as follows:

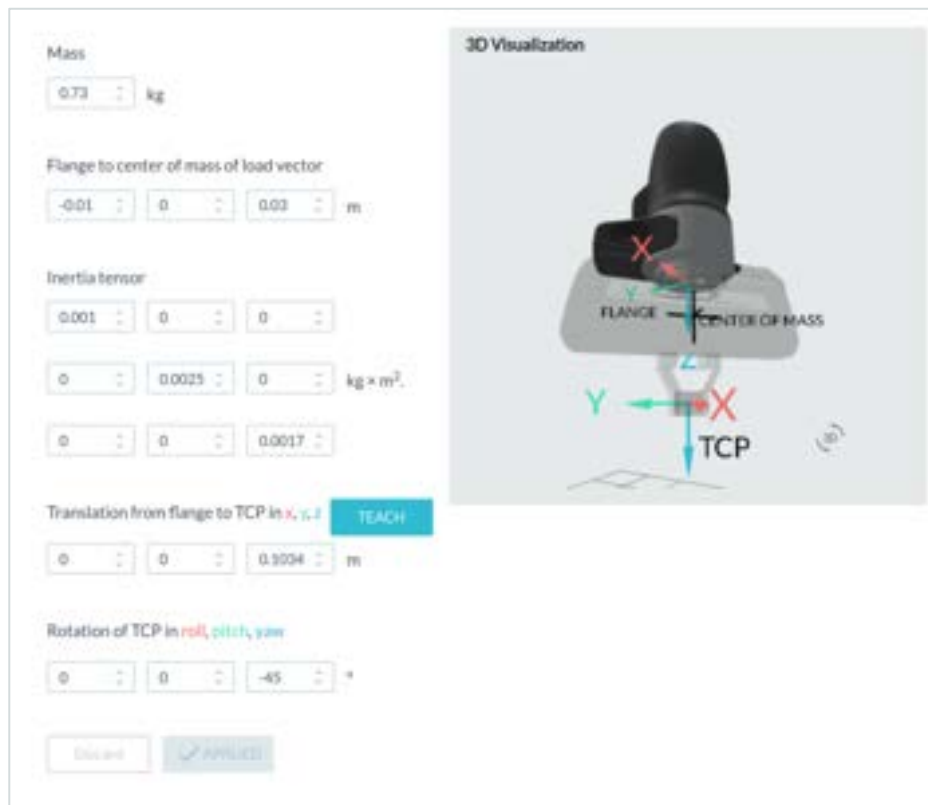

Figure 7.4: Screenshot default Settings

A correct configuration is essential for operating compatible robots of Franka Robotics. When configured incorrectly, gravitational forces are not entirely compensated and the Arm regulates to the wrong target values.

⚠ CAUTION

Unexpected moving of Arm

Incorrectly set mass and center of gravity values may lead to injuries, such as crushing.

- Check the mass and center of gravity for any end effector and the objects grasped by it.
- Correct the value if necessary.

When configured incorrectly:

- The Arm may pull towards certain directions in Guiding Mode.
- The regulation in Operating Mode may be affected so that the expected sensitivity of the Arm for collision detection is reduced.
- The tracking behavior may be affected.

For further information, refer to the Franka Production product manual.

If you are looking to attach additional tools between the Franka Hand and flange and therefore require a longer connection cable, see chapter 14 ADDITIONAL INFORMATION.

7.3.2 Integration in Watchman

When using the Franka Hand on compatible Franka robots, the settings for the monitoring safety functions in Watchman must be adjusted.

The safety behavior of the connected end effector is defined via the "End Effector Configuration". The following fields can be set:

- **Description:** Free editable description of the end effector.
- **SEEPO Behavior:** Determination of when and for which safety shutdowns the end effector is to be switched off.



Figure. 7.5: End Effector Configuration

- Safety Error: => Robot safety fault
- Safety Error /EM-Stop:=> Robot safety fault or Emergency Stop
- Safety Error/EM-Stop/Cat. 1 stop: Robot safety fault or Emergency Stop or Category 1 Stop
- Safety Error/EM-Stop/Cat. 1&2 stop: Robot safety fault or Emergency Stop or Category 1 or 2 Stop

In the default settings of the Robot is set "Safety Error/EM-Stop/Cat. 1 stop".

Power ON Behavior: Setting when the end effector is to be switched on.

- **Manual** =>With each switching on, the end effector must be activated manually in DESK.
- **Automatic** => The end effector will be automatically activated when the joints are unlocking.

In the default settings of the Robot „Automatic“ is preselected.

Creation of spheres

When an end effector is mounted, the control system needs information on its dimensions in order to be able to monitor the end effector spatially and kinetically. For this purpose, up to five spheres can be created and placed in their size and position so that the totality of the spheres resembles the contour of the end effector.

For spatial monitoring, the outer shells of the spheres are considered and for velocity monitoring, the centers of the spheres are considered. It should be noted that spheres placed far from the end effector flange can be very sensitive to velocity monitoring due to the lever consideration.

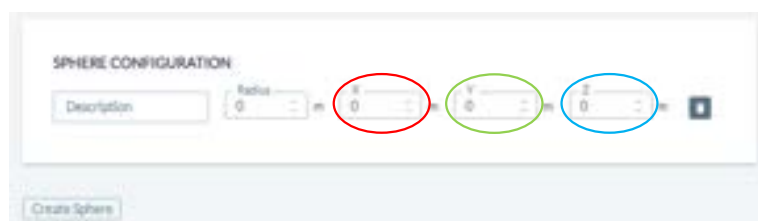

Figure. 7.6: Configuration of spheres

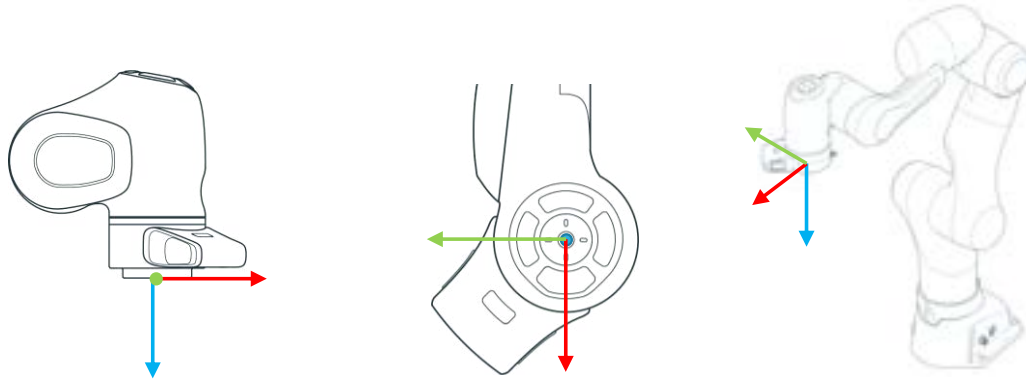

Figure. 7.7: Coordinate System of Flange

Below, an example of the sphere configuration of the Franka Hand is shown.

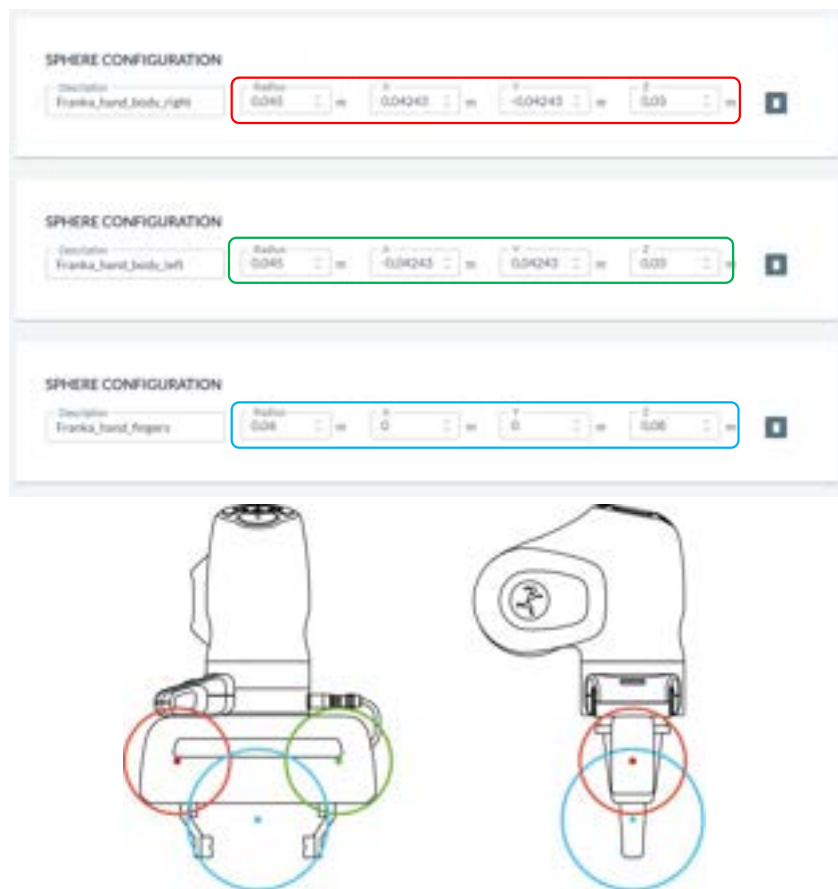

Figure. 7.8: Example of spheres for Franka Hand

If your gripping situation is not covered by the spherical model shown above, it must be adapted. Make sure that contours that could lead to collisions are covered by the sphere model. If you are handling longer objects, the maximum speed of cantilevered objects must also be monitored. To do this, you can place the centers of the spheres at the ends of the object. The maximum speed is monitored in the centers.

INSTALLATION

The following illustration shows an example of the Franka hand with a gripped rod. The spheres (yellow and purple) at the ends of the rod ensure that the maximum speed at the end of the rod is monitored.

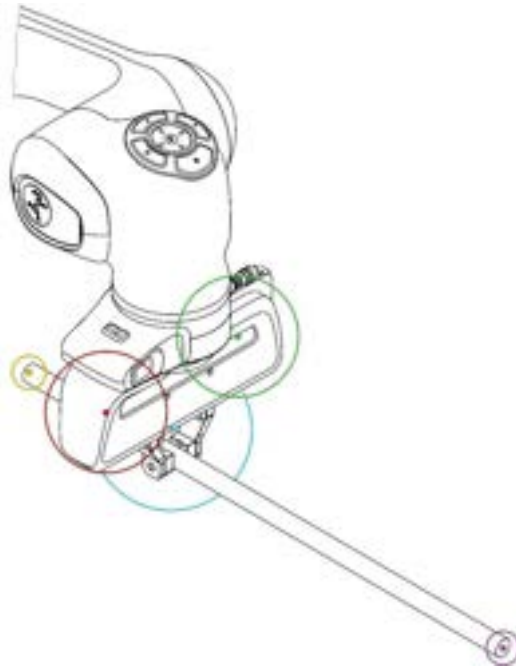

Figure. 7.9: Example of sphere configuration Franka hand with a rod

8 MAINTENANCE

8.1 Cleaning

DANGER

Risk of electric shock

Improper use of liquid cleaning agents as well as incorrectly disconnecting devices from the mains supply can lead to fatal accidents.

- Do not clean devices that have not been safely disconnected from the mains supply.
- Do not use liquid cleaning agents for cleaning the devices.
- Do not switch on devices that have not fully dried.

The following things need to be kept in mind while cleaning:

- Cleaning may only be carried out by qualified persons.
- Cleaning of components is only permissible when compatible robots of Franka Robotics are safely disconnected from the power supply (Control disconnected from the mains).
- Switching off and unplugging the device is to be carried out by qualified persons.
- Do not spray any liquids directly onto the device.
- Do not use any cleaning chemicals.
- The components may only be cleaned using a dry cloth. Make sure that no moisture enters the devices.
- Do not apply great force to the Arm. The parts to be cleaned are to be supported manually, so as not to overload and possibly damage the Arm.

NOTICE

Material damage to the end effector

Do not use liquid cleaning agents for cleaning the end effector.

8.2 Disposal

Disposal

Disposal of Franka Hand may only take place according to the relevant country-specific laws, standards, and regulations.

Return of packaging waste

Please contact Franka Robotics to process any returns of packaging waste.

9 SERVICE AND SUPPORT

NOTICE

If you have purchased your compatible Franka robot at one of our sales partners or if you have cooperated with a service provider, please get in contact with them first. Our partners can consolidate information on our products and reach out to Franka Robotics for troubleshooting and further support.

Please visit <https://franka.world> for supplemental material and additional information on our robots.

For any other requests regarding service and support please contact us at support@franka.de . A ticket for your request will be issued in our service and support center and our experts will respond as soon as possible.

10 PRODUCT CONFORMITY

10.1 Declaration of Incorporation

Declaration of Incorporation according to directive 2006/42/EC on machinery (Annex II B) for partly completed machinery	
Description of the partly completed machinery: Manufacturer: Franka Robotics GmbH; Frei-Otto-Straße 20; 80797 Munich; Germany Product identification: Franka Hand Model/Type: Franka Hand (#73912449) with running number starting from 2320001	
We declare that the product complies with the following essential safety and health requirements set out in Annex I of the Machinery Directive 2006/42/EC: 1.1.2; 1.1.3; 1.1.5; 1.1.6; 1.3.1; 1.3.2; 1.3.3; 1.3.4; 1.3.6; 1.3.7; 1.3.8; 1.3.8.1; 1.3.8.2; 1.4.1; 1.4.2.1; 1.5.1; 1.5.2; 1.5.4; 1.5.5; 1.5.6; 1.5.8; 1.5.9; 1.5.10; 1.5.11; 1.5.13; 1.7.1; 1.7.1.1; 1.7.1.2; 1.7.2; 1.7.3; 1.7.4; 1.7.4.1; 1.7.4.2; 4.4.1.2.3; 4.2.1	
In addition, the partly complete machinery is in conformity with the following EU Directives: Directive 2014/53/EU relating to electromagnetic compatibility (EMC) Directive 2011/65/EU relating to hazardous substances in electrical and electronic equipment (RoHS)	
We declare that the relevant technical documentation is compiled in accordance with part B of Annex VII.	
Applied harmonized standards:	
Electrical safety	
Standard EN 60204-1:2018 IEC 60204-1:2016	Name Safety of machinery - Electrical equipment of machines - Part 1: General requirements
Machinery safety	
Standard EN ISO 12100:2010 ISO 12100:2010	Name Safety of machinery - General principles for design - Risk assessment and risk reduction
EMC	
Standard EN IEC 61000-6-1:2019 IEC 61000-6-1:2016 EN IEC 61000-6-2:2019 IEC 61000-6-2:2016 EN 61000-6-3:2007 IAS 2011; AC 2012-08 IEC 61000-6-3:2007 EN IEC 61000-6-4:2019 IEC 61000-6-4:2018	Name Electrical compatibility (EMC) - Part 6-1: Generic standards - Immunity standard for residential, commercial and light-industrial environments Electrical compatibility (EMC) - Part 6-2: Generic standards - Immunity standard for industrial environments Electrical compatibility (EMC) - Part 6-3: Generic standards - Emission standard for residential, commercial and light-industrial environments Electrical compatibility (EMC) - Part 6-4: Generic standards - Emission standard for industrial environments
We commit to transmit, in response to a reasoned request by the market surveillance authorities, relevant documents on the partly completed machinery. The industrial property rights remain unaffected.	
Important note! The partly completed machinery must not be put into service until the final machinery into which it is to be incorporated has been declared in conformity with the provisions of Directive 2006/42/EC on Machinery, where appropriate, and until the CE Declaration of Conformity according to Annex II A is issued.	
Representative in EU, authorized to compile the relevant technical documentation: Franka Robotics GmbH Frei-Otto-Straße 20 80797 München Germany	Manufacturer: Franka Robotics GmbH Frei-Otto-Straße 20 80797 München Germany
Date, location 25.01.2024 Munich, Germany	Jin Zhengpou, CEO 
Document No.: K30001	Page 1/1

Figure 10.1: Declaration of Incorporation for partly completet mashinery

10.2 Further Statements

<p>Further Information</p> <p>status: 08.04.2022 Franka Hand</p>
<p>Restriction of Hazardous Substances (RoHS):</p> <p>The product <i>Franka Hand</i> does not fall within the scope of EU RoHS Directive 2011/65/EU, but still meets the requirements of the restricted substances and maximum concentration values that are allowed in homogenous materials:</p> <ul style="list-style-type: none"> • Lead (0.1 %) • Mercury (0.1 %) • Cadmium (0.01 %) • Hexavalent chromium (0.1 %) • Polybrominated biphenyls (PBB) (0.1 %) • Polybrominated diphenyl ethers (PBDE) (0.1 %) <p>The following exceptions are also applied: 6a: Lead as an alloying element in steel for machining purposes and in galvanized steel containing up to 0.35 % lead by weight 6b: Lead as an alloying element in aluminum containing up to 0.4 % lead by weight 6c: Copper alloy containing up to 4 % lead by weight</p>
<p>REACH:</p> <p><i>FRANKA Robotics GmbH</i> is a "downstream user" as defined in REACH. Our products are exclusively non-chemical products (manufactured items). In addition, under normal conditions of use and the conditions which can reasonably be predicted, no substances are released (Article 7, REACH). We confirm that our products do not contain more than 0.1 percent by mass of any of the listed substances on the published ECHA candidate list (SVHC). Extensions published by the ECHA candidate list are matched with our products and if it is known that one of these newly added substances is contained in our products, we will inform you immediately. This confirmation was created based on currently available information of our suppliers.</p>
<p>WEEE Directive:</p> <p>The product <i>Franka Hand</i> is not subject to the WEEE Directive 2002/96/EC for collection, recycling and recovery for electrical goods.</p>

Figure 10.2: Statements

10.3 Labeling



Figure 10.3: Label Franka Hand

11 USING THE FRANKA HAND

⚠ WARNING

Falling objects/tools

Objects or tools could fall at any time (e.g., due to loose couplings).

Malfunctions that can cause the Franka Hand to open or when a compatible robot is switched off, or the power to robot system is cut) which could lead to injury to fingers, Franka Hands, toes, and feet.

- Take this into consideration while performing a hazard and risk assessment.
- Take also the SEEPO into account in the risk assessment because the Franka Hand will only be powered if brakes are open due to a configuration of the SEEPO.

To control the end effector, press the Pilot-Mode button of the Pilot-Disc on a compatible Franka robot. The fingers of the Franka Hand can be steered via the arrow keys:

- A To slowly open the Franka Hand, keep the "left" key pressed.
- B To slowly close the Franka Hand, keep the "right" key pressed.
- C To open the Franka Hand to full width, press the "down" key once.
- D To make the Franka Hand grasp with its holding force, press the "up" key once.

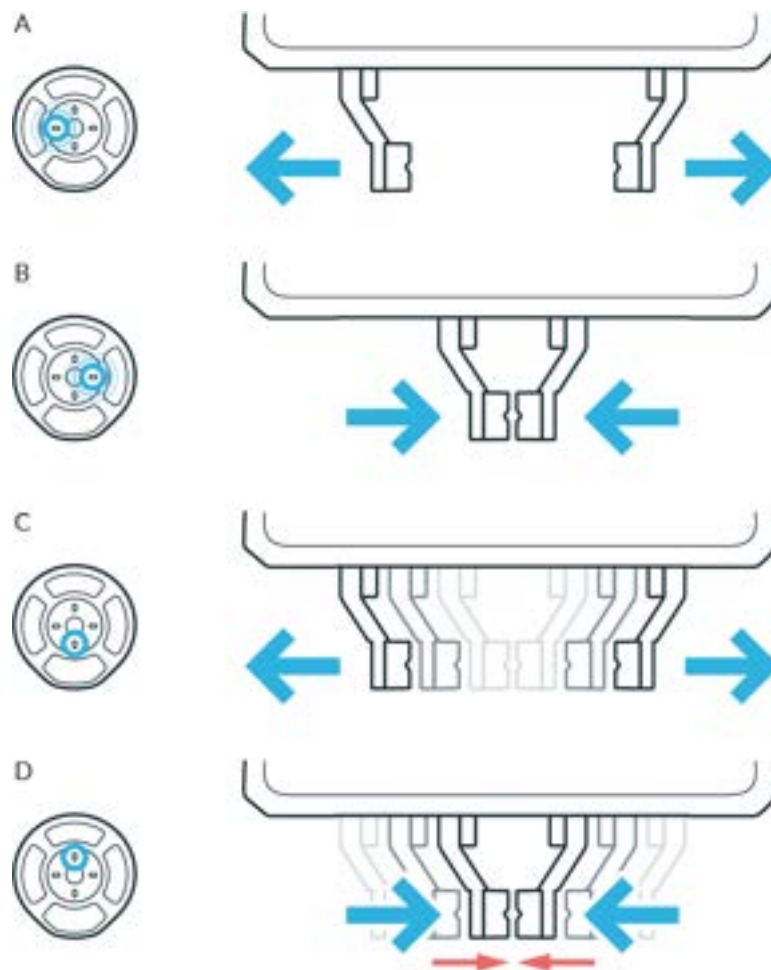

Figure 11.1: Control of Franka Hand movement

NOTICE

Material damage to the Franka Hand

The Franka Hand contains sensitive electromechanical components. These can be damaged if the Arm is moved into the transport position while the Franka Hand is still attached! Remove any end effector before bringing the Arm into the transport position.

Make sure that the Franka Hand has been removed before bringing the Arm into the transport position.

When the device is turned off, the Franka Hand is not supplied with power either. If the fingers of the Franka Hand are jammed, they can be loosened by simply pulling the fingers open.

12 CUSTOMIZING

Use Franka Robotics 3D Lab to customize fingertips. 3D Lab is a web-based user interface to design 3D-printable fingertips, for an ideal, ad hoc object grip with your Franka Hand.

Access Franka Robotics 3D Lab from <https://world.franka.de/fingertip-configurator>.



Figure 12.1: Franka Robotics 3D Lab

13 TROUBLESHOOTING

Desk shows Franka Hand "disconnected"

- Go to end effector settings and un-apply the Franka Hand as end effector by choosing "None".
- Choose "Franka Hand" again and press apply.
- If the Franka Hand is still disconnected:
 1. Shut down the robot.
 2. Check if the Franka Hand is connected properly or if any damages on the pins of the connector can be seen.
 3. Also check the connecting cable between Control and Arm for damaged pins or insufficient mounting.
 4. Reboot the robot.

Fingertips are not moving / fingertips are stuck in the middle of a movement

- If you cannot move the fingertips by Pilot-Disc buttons or command
 - Check the Settings of SEEPO (may the End Effector Power is switched off).
 - Check, if the apps or commands you are using are working with the correct settings.
 - Reboot the robot if necessary.
- If the fingertips get stuck, please check if
 - the fingers can be moved by Franka Hand (to exclude physical damage).
 - the apps or commands you are using are working with the correct settings.
 - Reboot the robot if necessary.

The Franka Hand does not work with real time commands

- Keep in mind that Franka Hand does not work with real time commands (applies only to research robots with FCI interface).

The Franka Hand is moving down/up while Hand guiding

- Check the settings for the end effector in the Franka UI's Settings.

14 ADDITIONAL INFORMATION

14.1 Extending the connector cable

To add an equipment mounting flange between Franka Hand and flange, extend the connector cable by adding an extension cable.

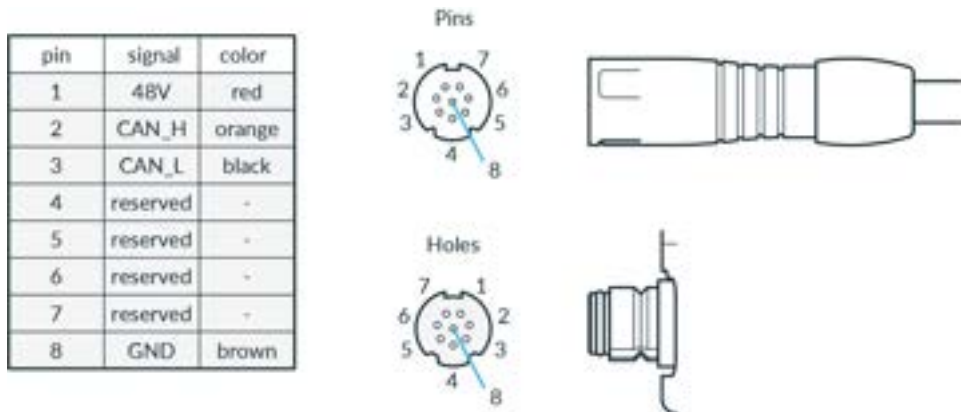

Figure 14.1: Electric Connection

A Binder 8-pin male/female connection: Snap-in IP67 Series 620 is required.

15 TABLE OF FIGURES

Figure 2.1: Overview Franka Hand	5
Figure 5.1: Coordinate system and centre of mass.....	11
Figure 5.2: Outer dimensions [mm].....	11
Figure 5.3: Dimensions of flange [mm].....	12
Figure 5.4: Travel range [mm]	12
Figure 5.5: Finger adaption interface [mm]	13
Figure 5.6: Fingertips interface [mm].....	14
Figure 5.7: Dimensions fingertips [mm]	14
Figure 6.1: Franka Hand	15
Figure 6.2: Additional material	15
Figure 7.1: Mounting of Franka Hand	18
Figure 7.2: Electrical connection.....	18
Figure 7.3: Screenshot Power Status.....	20
Figure 7.4: Screenshot default Settings	21
Figure. 7.5: End Effector Configuration	22
Figure. 7.6: Configuration of spheres	22
Figure. 7.7: Coordinate System of Flange.....	23
Figure. 7.8: Example of spheres for Franka Hand	23
Figure. 7.9: Example of sphere configuration Franka hand with a rod	24
Figure 10.1: Declaration of Incorporation for partly completet mashinery.....	27
Figure 10.2: Statements	28
Figure 10.3: Label Franka Hand	28
Figure 11.1: Control of Franka Hand movement	29
Figure 12.1: Franka Robotics 3D Lab	31
Figure 14.1: Electric Connection	33

16 INDEX

Additional required equipment	16	fastening torque.....	19
Arm	6, 19, 22, 26, 31, 33	Notice of liability.....	9
Cleaning.....	26	Pilot-Disc	30, 33
Components.....	16	Pilot-Mode	30
Finger	6	Plug	6
Interface/flange	6	Product Conformity.....	28
Plug.....	6	Declaration of Incorporation.....	28
Configuration.....	21	Protection class	17
Connector cable	33	Rights of use	7
Customizing.....	32	Safety.....	8
Default settings.....	22	Intended use	9
Disposal.....	26	Misuse.....	9
End effector configuration.....	21	Notice of liability.....	9
End effector flange	11, 17	Scope of delivery.....	16
Finger.....	6, 30	SEEPO	10, 18, 30
Fingertips.....	6, 32	Service.....	27
Flange/interface	6	Technical specifications.....	12
Franka Robotics GmbH.....	2, 29	Dimensions.....	12
Franka UI	7, 33	Finger adaption Interface.....	14
Guiding / Hand guiding.....	33	Fingertips.....	15
Guiding Mode.....	22	Fingertips Interface	15
Installation.....	17	Temperature	17
Intended use	9	Tightening torque	14
Labeling.....	29	Troubleshooting	33
Maintenance	26	Effector settings.....	33
Mechanical data	11	Reboot.....	33
Force	11	Watchman	10
Misuse	9	X6 connector	19
Mounting.....	18		

Franka Robotics GmbH
Frei-Otto-Strasse 20
80797 Munich
Germany